



**THE LAKES**  
AT VALLEY WEST

**The Lakes at Valley West  
DESIGN MANUAL**

**02 APRIL 2024**

---

**date**

**Prepared For:**

**The Lakes at Valley West, LLC**

**Prepared By:**





**DESIGN MANUAL**  
**Table of Contents**

<b>Name</b>	<b>Page</b>
Chapter 1: Purpose	5
Chapter 2: Properties and Projects Subject to Design Manual	5
Chapter 3: Relationship to other Documents	6
3.1 Local Land Use Regulations & Building Codes	6
3.2 The Declaration of Protective Covenants & Bylaws for The Lakes at Valley West	8
Chapter 4: The Lakes at Valley West Design Review Panel	9
4.1 Function	9
4.2 Membership	9
4.3 Enforcement Powers	9
4.4 Limitation of Responsibilities	9
Chapter 5: Design Review Process	10
5.1 In General	10
5.2 Informal Advice	11
5.3 Form 2: Sketch Design Review	12
5.4 Form 3: Construction Design Review	13
5.5 Form 4: Changes & Modifications	14
5.6 Building Permits & Site Plan Review	14
5.7 Timing of Construction	15
5.8 Inspections	15
5.9 Liability	16
Chapter 6: Neighborhood Design Patterns	17
6.1 Site	17
(a) Intent, Uses, Lot Coverage, Lot Area, Lot Width, Setbacks, Height, Garages, Parking and Minimum Density	17
(b) Fences & Screens	17
(c) Sidewalks	22
6.2 Building	22
(a) Recommended Energy Star Program	23
(b) Base Element & Foundation	23
(c) Walls & Façades	24
(d) Porches	25
(e) Outdoor Rooms	27

(f) Decks & Patios	27
(g) Windows & Solar Gain	28
(h) Doors	29
(i) Roofs	31
(j) Skylights	32
(k) Roof-Mounted Solar Panels	32
(l) Dormers	32
(m) Eaves	32
(n) Chimneys/Roof Vents	34
(o) Lighting	35
(p) Signage	35
6.3 Landscape	35
(a) Boulevard Plantings	36
(b) Yard Plantings	36
(c) Vegetation & Solar Gain	38
(d) Hardscapes	38
(e) Soil Preparation & Drainage	38
(f) Irrigation & Water Use	38
(g) Fertilizing	39
(h) Weed Control	39
(i) Vegetation Removal	39
6.4 Variations from Neighborhood Patterns	39
Chapter 7: Amendments	40
7.1 Floor Area Ratio	
7.2 Yards	
Chapter 8: Definitions	41
Exhibit 1: Phases 1 & 2 Legal Description	42
Exhibit 2: Phase 3 Legal Description	43
Exhibit 3: Phase 4 Legal Description	44
Exhibit 4: Phase 5 & 6 Legal Description	45
Appendix A1: Phases 1 & 2, The Lakes at Valley West PUD Zoning District	46
Appendix A2: Phase 3, The Lakes at Valley West PUD Zoning District	52
Appendix A3: Phase 4, The Lakes at Valley West PUD Zoning District	58
Appendix A4: Phase 5 & 6, The Lakes at Valley West PUD Zoning District	64

Appendix B: Forms (2, 3, 4, 5)

70

Appendix C1: Phases 1 & 2 Required Building Envelope Exhibits

Appendix C2: Phase 3 Required Building Envelope Exhibits

Appendix C3: Phase 4 Required Building Envelope Exhibits

Appendix C4: Phase 5 Required Building Envelope Exhibits

Appendix C5: Phase 6 Required Building Envelope Exhibits

Appendix D: Woonerf Diagram

Appendix E: The Lakes at Valley West Stormwater Maintenance Plan

Appendix F: The Lakes at Valley West Stormwater Maintenance Plan Update

Appendix G: City of Bozeman Approval for Modifications Aug. 16, 2018

Pursuant to the Declaration of Protective Covenants for The Lakes at Valley West (“Declaration”), on file with the Gallatin County Clerk and Recorder’s Office, the Declarant The Lakes at Valley West, LLC (“Declarant”), herein adopts the following The Lakes at Valley West Design Manual (“Design Manual”):

## **Chapter 1 : Purpose**

This Design Manual is intended to promote sustainable patterns of development that will encourage people to connect and interact as part of The Lakes at Valley West neighborhood and adjacent neighborhoods. The standards within this document provide a framework for design and construction that will allow each project to contribute to the neighborhood and to the long-term goal of complimenting and enhancing the overall Bozeman community. The architectural and landscape elements of site design are integral to the overall desired neighborhood patterns.

Rather than dictate specific design styles, the standards are provided to ensure well-built, compatible, energy-efficient homes with clear order and comprehensive composition. Photographs are included for education, inspiration and reference only and do not imply specific solutions or guarantee regulatory approval.

The goal is to strike a balance between neighborhood harmony and creativity. This document encourages design diversity and contemporary design while providing certain guidance to ensure quality design and longevity in property values. Each project should not simply be an exact copy of another building. The fact that a given style or feature of building already exists does not guarantee that it will be approved for construction again.

Exceptions to this Design Manual may be granted only based on architectural merit as determined by The Lakes at Valley West Design Review Panel (“DRP”) and outlined in Section 6.4. The DRP is not authorized to grant any exceptions to local land use regulations unless explicitly authorized by the appropriate review agency or agencies.

It is the responsibility of the Owner to ensure that all proposed construction shall comply with all laws, rules, and regulations including, but not limited to local Land Use Regulations and the International Building Code as well as other applicable plumbing, electrical, or building codes in effect for the City of Bozeman. The Declaration and Bylaws, if any, also apply to all Lots within The Lakes at Valley West Subdivision.

## **Chapter 2 : Properties and Projects Subject to Design Manual**

The Design Manual shall inure to and pass with each parcel, tract, lot or division in the Lakes Subdivision.

Unless specifically excluded, this Design Manual shall apply to the entire The Lakes Subdivision (as described in Exhibit 1, 2, 3 & 4), any property annexed to The Lakes Subdivision, and all improvements.

No improvements shall be made, erected, altered or permitted to remain upon any Lot until (1) the proper Form(s) is/are submitted, (2) any other information required or requested by the DRP is submitted, (3) all fees are fully paid, (4) all required Forms are approved in writing by the DRP, and (5) any applicable City of Bozeman review or permitting and/or fee payment(s) has been completed. All plans submitted to the City of Bozeman must have The Lakes at Valley West Design Review Panel Form 3 stamp of approval.

“Improvement” shall be construed broadly and includes, but is not limited to, a residence, fence, wall, garage, outbuilding, other structure, or landscaping.

## Chapter **3** : Relationship to other Documents

### 3.1 Local Land Use Regulations & Building Codes

All improvements must comply with applicable building codes, land use regulations, and all other laws, rules and regulations of any government or agency under whose jurisdiction the land lies. Local land use regulations can be found online at [www.bozeman.net](http://www.bozeman.net).

Some provisions of this Design Manual may be more restrictive, or less restrictive than local land use regulations as part of the overall The Lakes at Valley West Planned Unit Development (“PUD”).

3.1.1 The following relaxations from the Bozeman Municipal Code apply to The Lakes at Valley West Phase 1 and 2 Subdivision:

Relaxation #	Code Section	Summary of Section
#1	38.300.100.B	Intent of R-1 District
#2	38.310.030	Authorized Uses in R-1
#3	38.320.020.C	Lot Coverage and Floor Area
#4	38.320.020.A	Minimum Lot Area
#5	38.320.020.A	Minimum Lot Width
#6	38.320.020.F	Yards (Setbacks)
#7	38.320.020.D	Building Height
#8	38.360.040	R-1 Accessory Dwelling Units (ADUs)
#9	38.410.040.B	Block Length
#10	38.410.040.C	Block Width
#11	38.410.040.D.3	Pedestrian Walk Surface
#12	38.410.040.E	Block Numbering
#13	38.400.010.A	Design Standards (length of tangent at intersection)
#14	38.400.060.B	Alternate Alley Section to Allow Woonerf

Relaxations #1-8 are addressed in Appendix A1: The Lakes at Valley West PUD Zoning District and are intended to replace Article 3 in the Unified Development Code. Relaxations #9-14 are more related to overall subdivision design.

3.1.2 The following relaxations from the Bozeman Municipal Code apply to The Lakes at Valley West, Phase 3:

Relaxation No.	Code Section	Summary of Section
#1	38.300.100.B	Intent of R-1 District
#2	38.310.030	Expand Authorized Uses in R-1
#3	38.320.020.C	Increase Allowed Lot Coverage and Floor Area
#4	38.320.020.A	Reduce Minimum Lot Area
#5	38.320.020.A	Reduce Minimum Lot Width
#6	38.320.020.F	Reduce Yards (Setbacks)
#7	38.320.020.D	Replace Building Height in R-1 to be the same as R-4
#8	38.360.040	Allow R-1 Accessory Dwelling Units (ADUs) without a Conditional Use Permit for defined lots
#9	38.410.040.B	Allow Increased Block Length
#10	38.410.040.C	Allow Smaller Block Width
#11	38.410.040.D.3	Allow Alternate Pedestrian Walk Surface
#12	38.410.040.E	Block Numbering
#13	38.400.010.A	Design Standards (length of tangent at intersection)
#14	38.400.600.B	Alternate Alley Section to Allow Woonerf
#15	38.410.100.A.2	Reduction to minimum wetland setback
#16	38.410.080.F	% of front yard occupied by storm water facilities
#17	38.540.010.A.5	Parking in Side Yards at specific open space locations
#18	38.350.050.A.4	To allow covered decks exceeding 1/3 the length of the building to encroach 5-feet into the open space setback. To allow porches to encroach 5-feet into any yard facing a street or facing a Woonerf.

Relaxations #1-8, 17-18 are addressed in Appendix A2: The Lakes at Valley West PUD Zoning District and are intended to replace Article 3 in the Unified Development Code. Relaxations #9-16 are more related to overall subdivision design.

3.1.3 The following relaxations from the Bozeman Municipal Code apply to The Lakes at Valley West, Phase 4:

Relaxation #	Code Section	Summary of Section
#1	38.300.100.B	Intent of R-1 District
#2	38.310.030	Authorized Uses in R-1



#3	38.320.020.C	Lot Coverage and Floor Area
#4	38.320.020.A	Minimum Lot Area
#5	38.320.020.A	Minimum Lot Width
#6	38.320.020.F	Yards
#7	38.320.020.D	Building Height
#8	38.360.040	R-1 Accessory Dwelling Units (ADUs)
#9	38.410.040.B	Block Length
#10	38.410.040.C	Block Width
#11	38.410.040.D.3	Pedestrian Walk Surface
#12	38.410.040.E	Block Numbering
#13	38.400.060.A	Design Standards (length of tangent at intersection)
#14	38.400.060.B	Alternate Alley Section to Allow Woonerf
#15	38.410.100.A.2	Wetland setback

3.1.4 The following relaxations from the Bozeman Municipal Code apply to The Lakes at Valley West, Phases 5 & 6:

Relaxation No.	Code Section	Summary of Section
#1	38.300.100.B	Intent of R-1 District
#2	38.310.030	Authorized Uses in R-1
#3	38.320.020.C	Lot Coverage and Floor Area
#4	38.320.020.A	Minimum Lot Area
#5	38.320.020.A	Minimum Lot Width
#6	38.320.020.F	Yards
#7	38.320.020.D	Building Height
#8	38.360.040	R-1 Accessory Dwelling Units (ADUs)
#9	38.410.040.B	Block Length
#10	38.410.040.C	Block Width
#11	38.410.040.D.3	Pedestrian Walk Surface
#12	38.410.040.E	Block Numbering
#13	38.400.060.A	Design Standards (length of tangent at intersection)
#14	38.400.060.B	Alternate Alley Section to Allow Woonerf
#15	38.410.100.A.2	Reduction to minimum wetland setback
#16	38.420.060	Parkland Frontage
#17	38.350.050.A.4	Increase covered deck front yard encroachment

3.1.5 Notwithstanding anything contained in this Design Manual to the contrary, the relaxations set forth in 3.1.1, 3.1.2, and 3.1.3 may not be varied, amended, modified or deleted without the express written authorization of the City of Bozeman.

### **3.2 The Declaration of Protective Covenants and Bylaws for The Lakes at Valley West**

All Lots in The Lakes Subdivision are also subject to The Declaration of Protective Covenants for The Lakes at Valley West (“Declaration”), which are on file at the Gallatin County Clerk & Recorder’s Office, and Bylaws, if any. These documents are available for reference online at [www.valleywesthoa.org](http://www.valleywesthoa.org).

## **Chapter 4 : The Lakes at Valley West Design Review Panel**

A Panel is hereby established known as The Lakes at Valley West Design Review Panel (“DRP”).

### **4.1 Function**

The function and purpose of the DRP is to review applications, plans, specifications, materials, samples, and location to determine if the proposed construction conforms to the Declaration and the Design Manual.

### **4.2 Membership**

4.2.1 Before the Transfer Date, the Declarant may appoint a Design Review Panel composed of up to three persons. The persons are not required to be Owners or Members of the Association. The persons may serve on the Design Review Panel until he or she resigns or is replaced by the Declarant, whichever occurs first. If no persons are on the Design Review Panel, then the Board of Directors shall act as the Design Review Panel.

4.2.2 After the Transfer Date, the Board of Directors may appoint a Design Review Panel composed of up to three persons. The persons are not required to be Owners or Members of the Association. The persons may serve on the Design Review Panel until he or she resigns or is replaced by the Board of Directors, whichever occurs first. If no persons are on the Design Review Panel, then the Board of Directors shall act as the Design Review Panel.

4.2.3 The Board of Directors may also engage engineers or other advisors or consultants in the design review process as necessary.

### **4.3 Enforcement Powers**

Should any Owner violate or threaten to violate any part of this Design Manual, the DRP may attempt to work with the Owner to have the Owner cure the violation in a timely manner, and/or refer the violation or threatened violation to the Board of Directors. Among any other remedy set forth in the Declaration, the Board of Directors has the right to injunctive relief, which requires the Owner to stop, remove, and/or alter any improvements in a manner that complies with the standards established by the DRP.

#### 4.4 Limitation of Responsibilities

The primary goal of the DRP is to review the Review Applications and the plans, specifications, materials, samples, and location to determine if the proposed construction conforms to the Declaration and the Design Manual. The DRP does not assume responsibility for the following:

- The structural adequacy, capacity, or safety features of the proposed construction or improvement.
- Soil erosion, ground water levels, non-compatible or unstable soil conditions.
- Compliance with any or all building codes, safety requirements, and governmental laws, regulation or ordinances.

## Chapter **5** : Design Review Process

### 5.1 In General

5.1.1 Approval Required to Commence Construction. No improvements shall be made, erected, altered or permitted to remain upon on any Lot until the Owner submits the proper Form to the DRP and the Form is approved in writing by the DRP.

5.1.2 DRP Discretion. The DRP has complete discretion to approve, conditionally approve, or deny a Form. At the least, the construction, installation, or alteration shall comply with the Declaration and Design Manual; be in harmony with the external design, location, and topography of the surrounding Lots and The Lakes Subdivision; and not be placed on or under any part of said Lot within the common areas and easements reserved as indicated on Exhibit "A," or the common areas and easements reserved and created in the Declaration, except as approved by the DRP.

5.1.3 Information Required. No Form will be deemed submitted until all information required by the Design Manual and requested by the DRP, and all fees are provided. Incomplete applications may be returned and are subject to a re-submittal fee.

5.1.4 Submitting Forms. Submit (by email, hand delivery, mail, or online at [www.valleywesthoa.org](http://www.valleywesthoa.org)) copies of the required Form and related materials for each design review to the following:

**The Lakes at Valley West Design Review Panel**  
c/o Intrinsic Architecture, Inc.  
106 East Babcock Street Suite 1A  
Bozeman, Montana 59715

Submittals must be labeled with "The Lakes at Valley West Design Review Panel" and specific project title and address. Form 2, Form 3, Form 4, and Form 5, as may be amended from time to time, may be requested from the DRP or the Association's property manager.

5.1.5 After the Review. Following DRP review, the Owner will be notified as to whether the construction has been approved, conditionally approved or denied.

5.1.6 Withdrawing Application. An Owner may withdraw an application without prejudice, provided the request for withdrawal is made in writing to the DRP.

5.1.7 Variances. Any request for any variance must be made in writing to the DRP. Any variance granted shall be considered unique and will not set any precedent for future decisions. Variance requests are subject to Section 6.4.

5.1.8 Request for Hearing. If an application is conditionally approved or denied, the Owner may request a hearing before the DRP to justify the Owner's position. The DRP will consider the arguments and facts presented by the Owner and notify the Owner of its decision.

5.1.9 Event of Inaction. If the DRP does not act on or respond to a Form within forty-five days after receiving the Form, the Form shall be deemed denied.

## 5.2 Informal Advice

Prior to beginning the design process, it is recommended that Owners and their designated representatives (such as architects, contractors, etc.) contact the DRP to verify their interpretation of this Design Manual. Owners or their designated representatives may, at their option, request a meeting with the DRP to discuss the preliminary plans prior to a full Form 2 (Sketch Design Review) submittal.

<b>Fee*</b>	<b>Required Documents</b>	<b>Required Submittal Materials (2 paper copies + 1 digital PDF copy)</b>	<b>Schematic Drawing Checklist</b>
None (except as noted below)	None	Conceptual plans appropriate for informal discussion	N/A

\*Note: Additional meetings and/or reviews requested by the Owner and as determined by the DRP to be above and beyond the standard review process are subject to hourly fees in addition to the Design Review fee and must be paid prior to issuance of approval.

### 5.3 Form 2 (Required) Sketch Design Review

The Sketch Design Review checks designs for general interpretations of the overall Declaration and Design Manual. Form 2 includes a statement of Acknowledgement. The Lot Owner and/or its designated representative shall take all necessary steps to ensure that they and their employees, subcontractors, agents, suppliers, and others involved in the development of the Lot are familiar with and agree to abide by the Declaration, Design Manual, and approved plans.

Note that Form 2 review **must be** completed before Form 3 review can begin.

If a Form 3 application is not submitted within 9 months of Form 2 review (based on the date of the letter from the DRP approving or conditionally approving the plans) or if the design changes considerably (as determined by the DRP in the DRP’s sole discretion), a new full Form 2 submittal will be required.

Fee*	Required Documents (1 paper copy + 1 digital PDF copy)	Required Submittal Materials (1 paper copy + 1 digital PDF copy) <i>Half size/scale plots acceptable.</i>	Schematic Drawing Checklist
\$600	Form 2 (must be signed)	Site Plan (1/16" or 1/8" scale)	North Arrow Property/Setback Lines Easements Sidewalks; Building Footprints; Porches, Stairs, etc; Overhangs (as dashed lines)
		Landscape Plan (1/16" or 1/8" scale)	Schematic Site & Boulevard Landscaping
		Floor Plans (1/8" scale or larger)	Room Use Windows & Doors Overhangs Dimensions Gross SF

		Elevations (1/8" scale or larger)	Porches, balconies Doors, windows Materials specified Overall Height (from average grade) Roof Pitches
--	--	--------------------------------------	--

**\*Notes:**

- 1) Fee covers Form 2 & 3; if project does not progress past Form 2, a \$400 refund will be provided upon request of the owner.
- 2) Additional meetings and/or reviews requested by the Owner and as determined by the DRP to be above and beyond the standard review process are subject to hourly fees in addition to the Design Review fee and must be paid prior to issuance of approval.
- 3) Incomplete applications may be returned and are subject to a \$100 penalty.

## 5.4 Form 3 (Required) Construction Design Review:

The Construction Design Review checks the construction documents for general compliance with the Declaration and Design Manual and verifies that the previous DRP recommendations have been addressed. Conformity to applicable local regulations and building codes, as well as obtaining appropriate permits is the responsibility of the Owner and/or the Owner's architect and/or builder.

If a Form 3 application is not submitted within 9 months of Form 2 review (based on the date of the letter from the DRP) or if the design changes considerably (as determined by the DRP in its sole discretion), a new full Form 2 submittal will be required.

Fee*	Required Documents (1 paper copy + 1 digital PDF copy)	Required Submittal Materials (1 paper copy + 1 digital PDF copy) <i>Half size/scale plot acceptable.</i>	Drawing Checklist
\$0	Form 3 (must be signed) & Green Building Checklist	Site Plan (1/16" or 1/8" scale) All dimensions must be noted.	North Arrow; Property Lines; Setback Lines; Easements; Sidewalk & Street Location; Location, Dimensions, Materials for walks & drives; Building Footprints; Porches, Stairs, etc.; Overhangs (as dashed lines); Fence location & details; Grading Plan; Location and screening of equipment and meters; Limits of construction activity
		Landscape Plan (1/16" or 1/8" scale)	Site landscaping Boulevard Landscaping
		Floor Plans (1/8" scale or larger) All dimensions must be noted.	Room Use Windows & Doors Overhangs Gross square footage for unit and garage

		Elevations (1/4" scale or larger) All dimensions must be noted.	Porches, balconies Doors, windows Materials specified Overall Height (from average grade) Roof Pitches Lights and light fixture details
		Color Rendering	Color rendering of the front elevation and color chips
		Material Samples	As requested by DRP
		Foundation Letter from Engineer	Each project is required to submit a letter from a civil engineer identifying existing ground water elevations, and recommendations for foundation design, footing and first floor elevations.

\*Notes:

- 1) Fees paid with Form 2 cover both Form 2 & Form 3.
- 2) Form 2 & Form 3 may be submitted concurrently.
- 3) Additional meetings and/or reviews requested by the Owner and as determined by the DRP to be above and beyond the standard review process are subject to hourly fees in addition to the Design Review fee and must be paid prior to issuance of approval.
- 4) Incomplete applications may be returned and are subject to a \$100 penalty.

## 5.5 Form 4 Changes & Modifications:

Owners may wish to make improvements or modifications to their improvements or property during the initial construction or at a future date. A change may only be executed after DRP approval of Form 4. **Note that any changes or modifications that are made before Form 4 is submitted, reviewed, and approved will be subject to a penalty, to be decided by the Board of Directors or the DRP.**

Fee*	Required Documents (1 paper copy + 1 digital PDF copy)	Required Submittal Materials (1 paper copy + 1 digital PDF copy)	Drawing Checklist
None (except as noted below)	Form 4	Any relevant drawings related to proposed change(s)	Any details related to the proposed changes.

\*Notes:

- 1) Additional meetings and/or reviews requested by the Owner and as determined by the DRP to be above and beyond the standard review process are subject to hourly fees in addition to the Design Review fee and must be paid prior to issuance of approval.
- 2) Incomplete applications may be returned.

## 5.6 Site Plan Review & Building Permits

All construction projects require a building permit and some projects may require additional review from the City of Bozeman. Any plans submitted to the City of Bozeman must include The Lakes at Valley West Design Review Panel stamp and/or letter of approval. This is a

requirement of The Lakes at Valley West Homeowners' Association and not the City of Bozeman.

Approval by the DRP does not guarantee approval by the City of Bozeman.

Construction may not commence without obtaining necessary approvals/permits from the City of Bozeman and the Valley West Home Owner's Association. The Valley West Homeowners' Association will assess significant fines for beginning construction prior to obtaining all required approvals.

### **5.7 Timing of Construction**

An Owner has 1 year from the date of Form 3 approval to start construction. If construction of a structure is not started within 1 year of Form 3 approval, new approval must be obtained.

An Owner has 1 year from the date construction commences to complete construction, unless an extension is granted by the DRP. If construction is commenced and is not completed in 1 year or is not completed in strict compliance with what was approved, then in addition to any other remedy allowed in the Declaration or this Design Manual, or at law or in equity, the Board of Directors, may, in its sole discretion, take any action that in its judgment is necessary to improve the appearance of the construction or to bring it into compliance with the Declaration, the Design Manual, or the approved plans, including completing the exterior, or removing the uncompleted structure, or any other action. Consideration will be given to remaining landscaping based on seasonal constraints; however, such landscaping must be completed during the beginning of the next planting season. The amount of any expenditure incurred in so doing shall be the Owner's obligation. In addition, a lien on the Lot may be recorded and enforced by an action at law. The Association may also take such action as is available in the Declaration and by law or in equity, including an injunction and/or action for damages.

### **5.8 Inspections:**

The DRP reserves the right to inspect the Lot during any stage of construction. If the DRP determines, in its sole discretion, that discrepancies exist between the construction and approved plans, the Declaration, or the Design Manual, the Owner shall immediately correct the discrepancies or submit a Form 4 (after the fact changes) for review and approval.

A Final Inspection is required. Owners are responsible for scheduling an inspection.

The inspection shall determine general compliance with the Declaration, Design Manual, and approved plans. If the DRP finds the improvements were not completed in strict compliance with the Declaration, Design Manual, and approved plans, the DRP shall notify the Owner of the noncompliance, and shall require remedy of the same. The Owner shall have 7 days from the notification to remedy the noncompliance or to submit a work plan delineating the time frame when the noncompliance will be remedied, although in no instance shall the timeframe exceed 45 days. The DRP may allow up to 45 days for the noncompliance to be remedied if



the Form 4 and corresponding work plan provides adequate justification for the requested time.

If the noncompliance is not remedied, the Board of Directors may, in its sole discretion, remedy the noncompliance. The amount of any expenditure incurred in so doing shall be the Owner's obligation. In addition, a lien on the Lot may be recorded and enforced by an action at law. The Association may also take such action as is available in the Declaration and by law or in equity, including an injunction and/or action for damages.

No occupancy of the project shall take place prior to the completion of all required inspections or as otherwise specified by the DRP.

### **5.9 Liability**

Neither The Lakes at Valley West Homeowners' Association, the Declarant, the Board of Directors, the DRP, nor the individual member's thereof, may be held liable to any person for any damages for any action taken pursuant to this Design Manual, including but not limited to, damages which may result from review, correction, amendment, changes or rejection of plans and specifications, observations or inspections, the issuance of approvals, or any delays associated with such action on the part of the Design Review Panel or Board of Directors.

# Chapter **6** : Neighborhood Design Patterns

All development must adhere to the neighborhood patterns described in the following sections (Site, Building, and Landscape). Photos are included reference only. Note that some provisions of this Design Manual may be more restrictive, or less restrictive, than local land use regulations as part of the overall Planned Unit Development (PUD). See Section 6.4 for allowable variations from these neighborhood patterns. **Please also refer to Exhibit C1 & C2 for specific lot by lot requirements for uses, setbacks, coverage, areas, widths, etc.**

## 6.1 Site

The following site design guidelines are intended to provide a framework for site layouts within The Lakes at Valley West.

(a) Regulations regarding **Intent, Uses, Lot Coverage, Lot Area, Lot Width, Setbacks, Height, Garages, Parking and Minimum Density** are all addressed in Appendix A1 & A2: The Lakes at Valley West Planned Unit Development Zoning District.

### (b) Fences & Screens

- No fencing is allowed in street-facing yards or in required street vision triangles (excluding corner lot side yards, see note below).
  - Fences (max. height of 42") are allowed to be placed in (1) corner side yard on corner lots with two street- or woonerf-fronting yards. In no circumstance is fencing allowed to fully enclose a front porch. Unencumbered pedestrian access between the front porch and the street is required. See acceptable 42"-tall fence designs below.
  - Fencing may not extend beyond the front wall plane of a structure, which is defined as the wall containing the front door.
- The following fence types are permitted. See specifications below.
  - A 42" tall fence, only as specified below, is allowed along the woonerf property lines and along an imaginary line setback two feet inside any property line that borders park or open space. It is also allowed on common private property lines and returns to the house structure. The two-foot buffer between the fence and the property line bordering park or open space must be planted with a well-maintained planting bed with a top layer of mulch or earth tone stone.

### 42" Height (3' 6" H) Option A

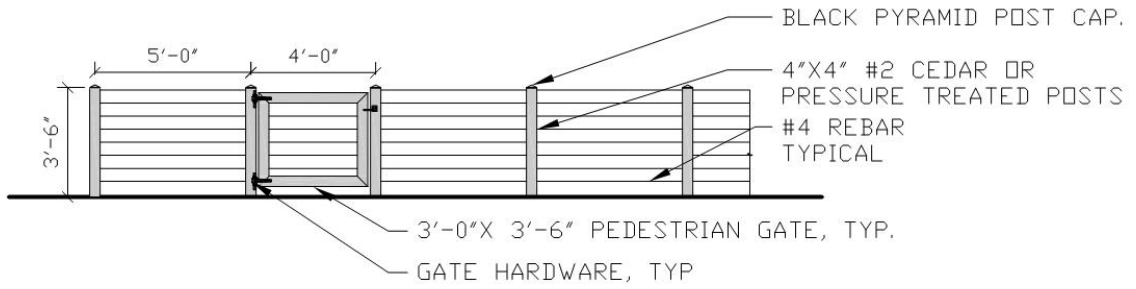

OPTION A

### 42" Height (3' 6" H) Option B

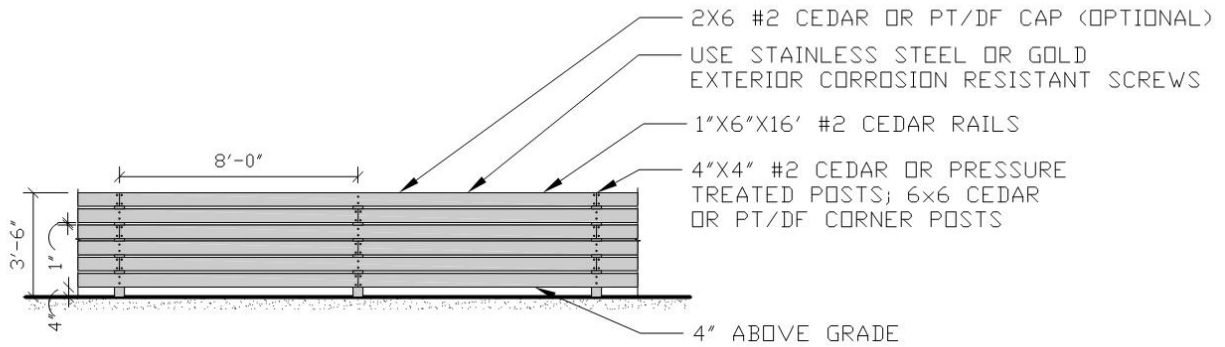

OPTION B

### 42" Height (3' 6" H) Option C

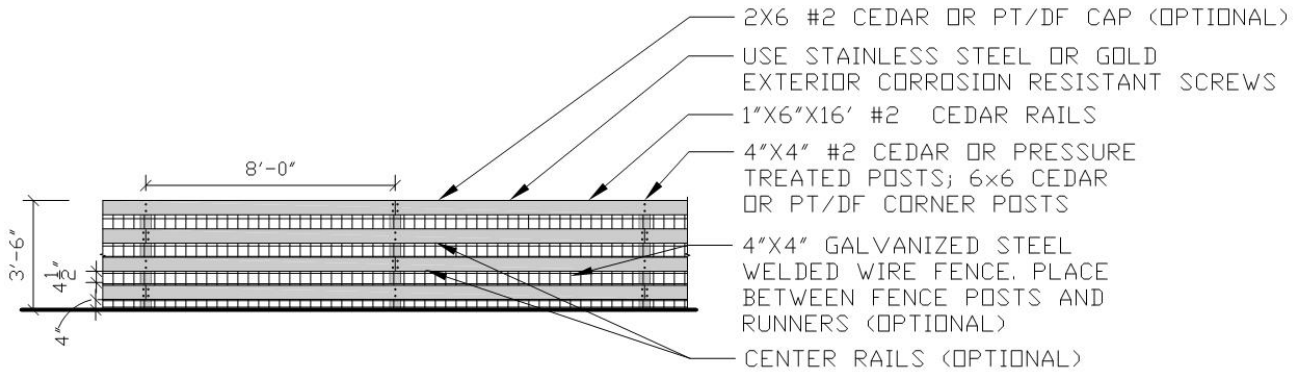

OPTION C

**42" Height (3' 6" H) Option D**

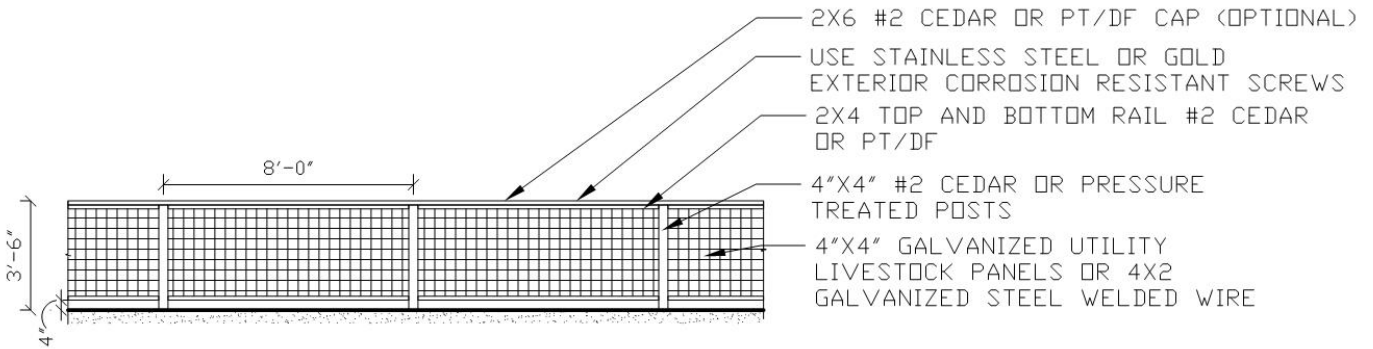

OPTION D

- A 4-foot-tall fence, only as specified below, is allowed on common private property lines and returns to the house structure.

**4' Height Option A**

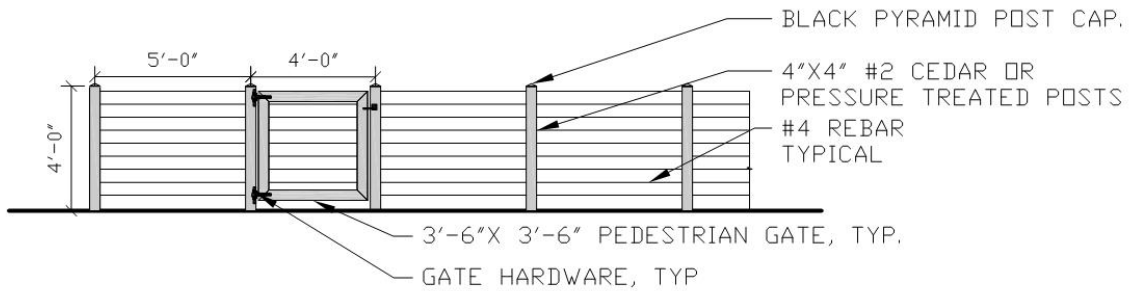

OPTION A

### 4' Height Option B

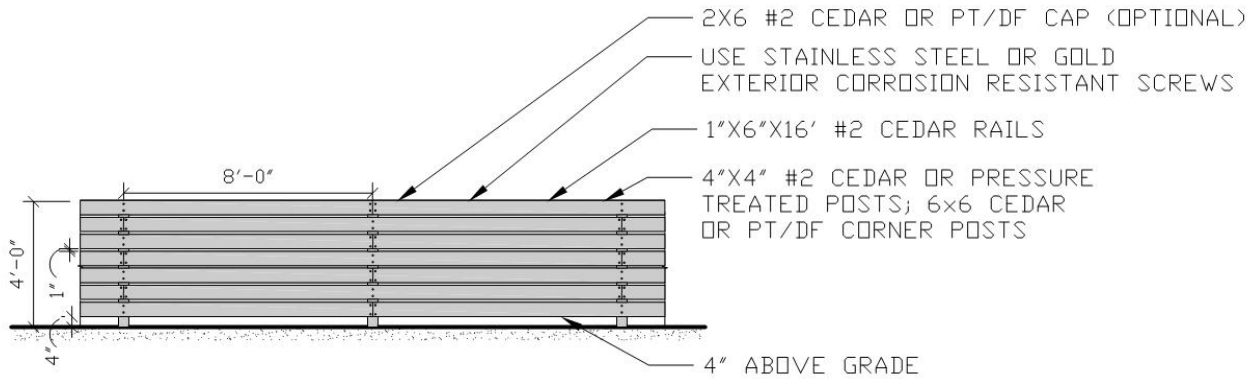

OPTION B

### 4' Height Option C

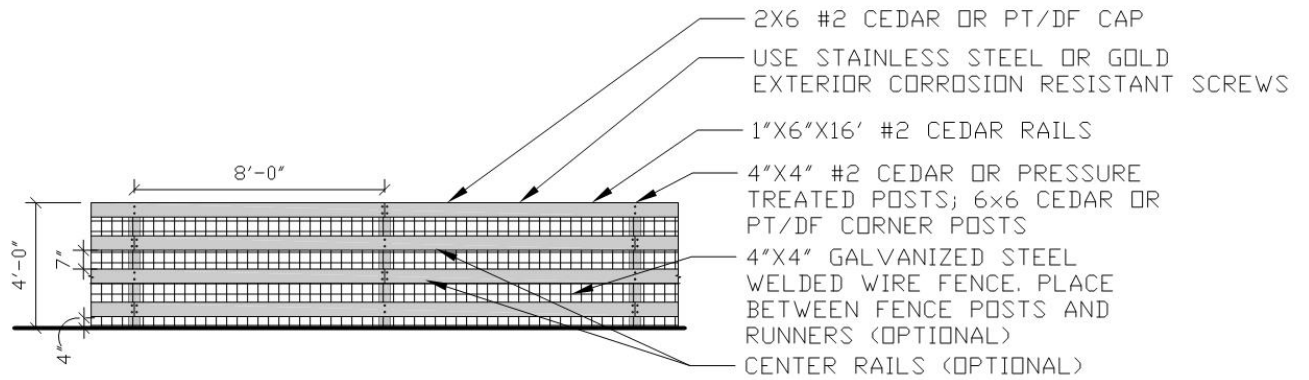

OPTION C

### 4' Height Option D

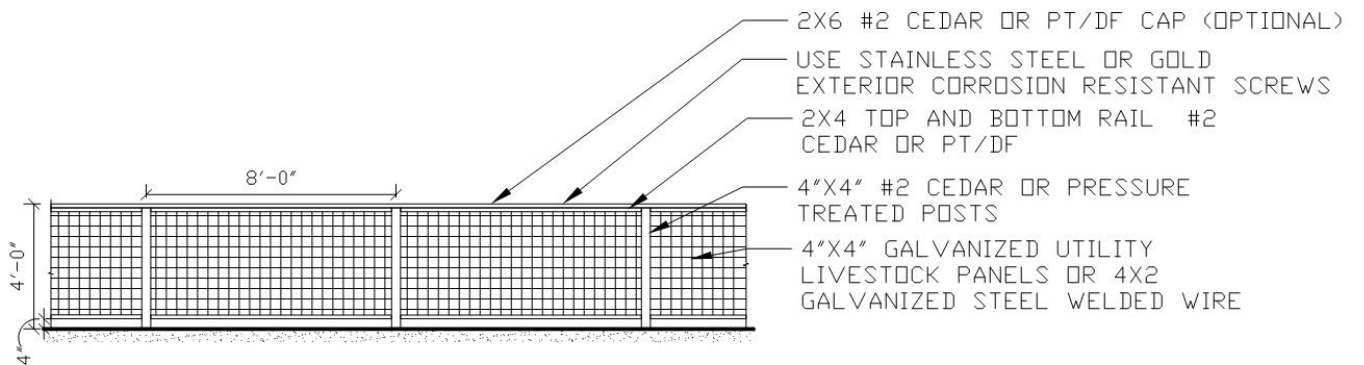

OPTION D

- A 6-foot-tall screen fence, only as specified below, is allowed on side property lines setback 20 feet from the street and woonef property lines and allowed on returns to the house structure.

**6' Height Option A**

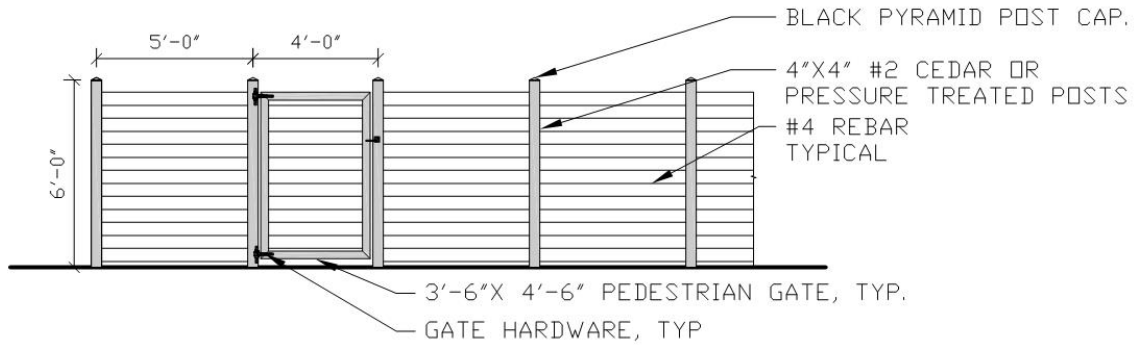

OPTION A

**6' Height Option B**

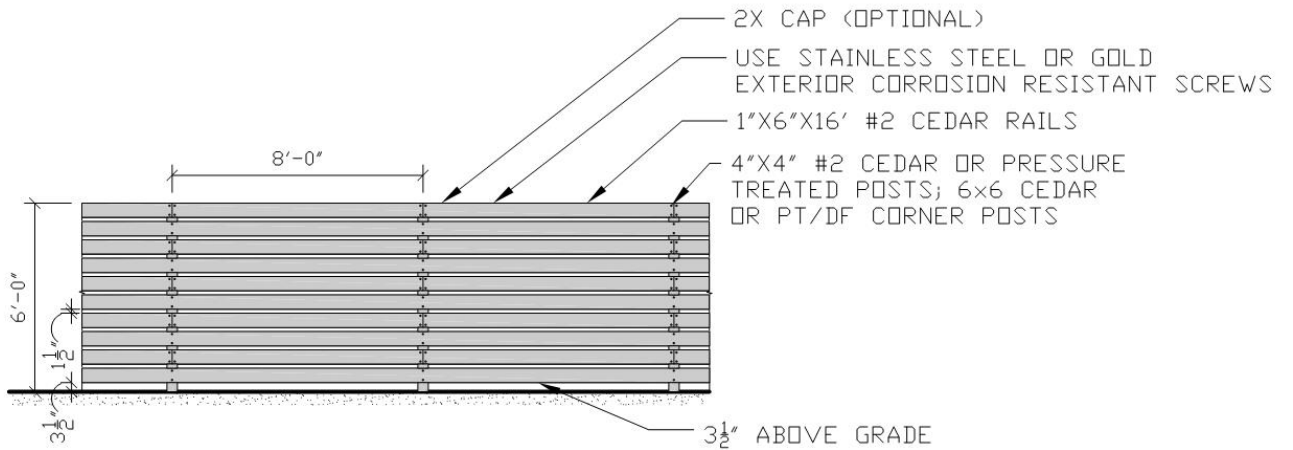

OPTION B

- All fence connections shall be made with stainless steel or gold exterior corrosive resistant screws.
- All fences shall be stained or sealed to protect them from weather and elements and to maintain appearance.
- Screen walls, used for patios or hot tubs, are required to meet all setbacks and must be aesthetically connected to and appear as an extension of a primary residence wall. Outdoor rooms may be designed to include, but shall not be substantially obscured by, screen walls.

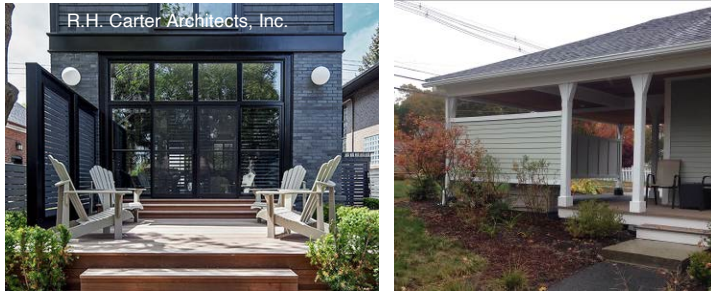

- All fence assemblies are required to be maintained for appearance and kept in working order.
- Dog kennels or runs must be attached to a primary or accessory structure, be screened from public streets and adjacent properties, and receive DRP approval for materials and configuration. Chain-link is not permitted. Underground electric fences are encouraged for dogs.
- Utility panel or wire fences must be constructed so that the wire or utility panel is attached and held in place by the fence structure. Staples, alone, are not acceptable to attach the wire to the fencing frame.

### **(c) Sidewalks**

- Any existing sidewalks in the right-of-way or open spaces that are damaged during construction must be repaired or replaced at the lot owner's expense.
- Sidewalks on homes facing local streets are required to cross the boulevard in line with the sidewalk leading to the front porch.
- Upon the third anniversary of the plat recordation of any phase of the subdivision, any lot owner who has not constructed said sidewalk shall, without further notice, construct within 30 days, said sidewalk for their lot(s), regardless of whether other improvements have been made upon the lot. Failure to comply may result in the HOA constructing sidewalks and assessing full coordinating and installation costs and apply fines when deemed necessary.

## **6.2 Building**

The following building design guidelines are intended to promote both building diversity and neighborhood compatibility within a developing neighborhood framework.

**(a) Recommended Energy Star Program**

- Because of its ease and low cost, homes are encouraged to meet or exceed the standards of the “Energy Star” Program. Energy Star homes typically include additional energy-saving features that make them 20–30% more efficient than standard code compliant homes.
- Energy Star Qualified New Homes include:
  - Effective Insulation
  - High-Performance Windows
  - Tight Construction and Ducts
  - Efficient Heating and Cooling Equipment
  - Efficient Products
  - Third-Party Verification
- The specific standards can be found at:  
[http://www.energystar.gov/index.cfm?c=new\\_homes.hm\\_index](http://www.energystar.gov/index.cfm?c=new_homes.hm_index).

**(b) Base Element & Foundation**

- A base element is required and must be detailed in such a way to visually and structurally connect the building with the ground. It may appear as a platform or terrace upon which the house stands or as a built extension of the ground integrated with the house above. This element may be masonry, concrete, wood or materials matching trim package. Buildings without a base element may be considered based on design merit.



- Foundation walls shall be exposed a maximum of 12-inches above the ground. Exposed foundation walls shall be built of brick, cast concrete, trimmed with horizontal members, or as otherwise approved by DRP. Concrete foundations exposed more than 18-inches above grade must have an architectural finish (texture, pattern and/or color).





- Due to the potential of high ground water tables in the areas of the subdivision, it is not recommended that residential dwellings or other structures with full or partial basements be constructed without first consulting a professional engineer licensed in the State of Montana and qualified in the certification of residential and commercial construction.

### **(c) Walls & Facades**

- All facades of the main building and accessory structures shall be made of similar materials and be similarly detailed.
- Primary materials on a façade may change only at a horizontal band or an inside corner. Consideration will be given to changing materials at a visual block such as a fence.
- Varied building massing is encouraged. No exterior wall plane, unless approved otherwise for design merit, shall exceed 35 feet in length without incorporating a minimum 24-inch offset or recess in a significant proportion to the overall plane.
- Building walls shall be clad in smooth cut wood shingles, wood clapboard, barn or reclaimed wood, wood drop siding, traditional wood board and batten, fiber cement siding, architectural metal cladding, brick, or stone. Siding shall be painted or stained; pre-finished siding will be considered based on design merit. Alternative materials, including the use of steel, will be considered based on design merit. Stucco, log, vinyl or aluminum siding is not allowed.



- The color palette of the body of the house shall be as approved by the DRP based on merit. Color schemes must be varied from the two adjacent properties, in each

direction and from the properties across the street. Attached dwelling units are exempted from each other. Garish colors are not allowed.

- Exposed exterior wood shall be painted or stained (wood front doors excluded).
- Lap siding shall run horizontally. Maximum lap siding exposure is 5-inch. Combinations of lap exposure will be considered on a case-by-case basis.



- Trim materials should be of high quality and of appropriate visual size. Exterior trim of at least 4-inches is required around windows and doors. Corner caps are acceptable. Variations on trim width and/or exclusion of trim will be considered based on design merit.
- Brick surfaces shall be set predominantly in a horizontal running bond pattern.
- Stonework shall be natural or approved synthetic stone materials. Dry stack, uncoursed settings with minimal exposed mortar are preferred. Stonework shall not be applied to individual wall surfaces to avoid a veneer-like appearance. It shall continue around corners to an inside corner.

#### **(d) Porches**

- For yards facing a public street, the front porch of a residential structure must be built within 5 feet of the setback line (“build-to” line). The width of the porch on the build-to line must occupy a minimum of 30% of the width of the front façade measured along the build-to line. As an alternative to the typical front porch and to provide additional design diversity, narrower but deeper porches that have the same square footage may also be considered. A minimum 6 feet of depth is required.



- Buildings on lots that address two or more streets must address both streets with fronting characteristics as part of the comprehensive composition. Design considerations should include but not be limited to: wrapping front porches, outdoor rooms, variation in wall planes and massing, additional openings and enhanced landscaping.
- Porches are also required along woonerfs; however, these porches only have a minimum length or width requirement of 6 feet. The percentage requirement does not apply to porches facing a woonerf.



- Front porches generally must be elevated between 2 and 4 feet above fronting top of curb. Other heights may be considered based on-site conditions and foundation design.
- Porch railings may be opened or closed. If closed, they must be constructed of the same material as the adjacent wall planes.
- Front stoops shall be made of concrete, wood, stone, or brick and must be detailed and integrated into the porch/railing design. Required stair railings must be compatible with the overall stair and porch design.
- Porch supports shall be built of stone, masonry, concrete, or wood. Column base piers shall be no less than 16 x 16-inch square and wood columns shall be no less than 8-inches square. Column groupings must have an outer minimum dimension of 10-inches. Tapered columns may not be smaller than 7 x 7-inches at the top. Columns shall match or be similar in design on all elevations of a structure.
- The balustrade and the space below porches shall be closed and integrated into a closed band and/or landscaped, interrupted as necessary for drainage.
- No exposed stair or deck framing is allowed.





**(e) Outdoor Rooms (required on buildings adjacent to open spaces)**

- To complement the neighborhood open spaces and courtyards, all lots adjacent to an open space are required to have an “Outdoor Room” facing the open space. This concept is intended to provide a transition from the public green spaces to private indoor spaces. Buildings on lots that address two or more open spaces will only be required to address one open space with an outdoor room. The building, however, will need to address all open spaces. Design considerations should include but not be limited to: wrapping front porches, outdoor rooms, variation in wall planes and massing, additional openings, and enhanced landscaping.



- The minimum size requirement for an outdoor room is 80 square feet with a minimum dimension of 8 feet on both sides.
- Outdoor Rooms typically include covered porches, screened porches, covered patios, or covered decks with integrated landscaping. Partially covered or uncovered patios or decks that are integrated into the overall design and comprehensive composition of the home and landscaping will be considered on design merit.
- Other interpretations of outdoor rooms will be considered based on design merit by the DRP.

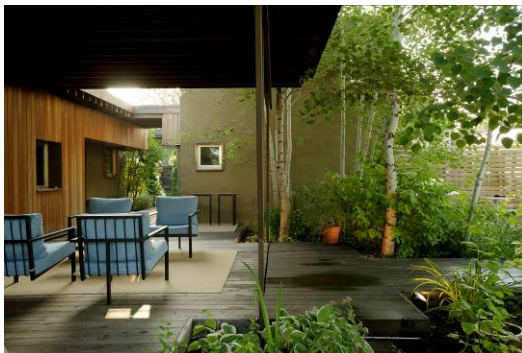

**(f) Decks & Patios**

- Decks and patios must face only side yards and/or open spaces. Decks and patios may not extend more than 40 percent feet into any required side setback.

Setback	Deck/Patio Encroachment
5'	2'
7'	2'-9"
10'	4'
12'	4'-9"

- Within The Lakes at Valley West, Phase 3, Lots 5-12, first and second floor porches fronting Durston Road may encroach up to 5' into a 10' open space setback only if the covered deck exceeds 1/3 in length of the building.
- The space below first floor elevated decks visible from nearby streets or public spaces shall be architecturally detailed and/or landscaped to provide screening.
- Decks, balconies, and terraces shall be designed to enhance the overall architecture of the building by creating variety, layering, and detail on exterior elevations. Covered decks, projecting balconies, and bay windows shall be integrated and composed with the overall building form, rather than placed randomly throughout the building. Terraces shall be used to integrate the building and landscape by creating a transition between the built and natural character of the site.

### (g) Windows & Solar Gain



- Windows are encouraged meet or exceed Energy Star standards as previously stated.
- Openings (including windows and doors) shall not be less than 15% of the wall area, measured on each elevation. Elevation calculations shall include exterior window or door trim.
- Windows shall be wood, wood-clad, fiberglass or vinyl.
- Round, hexagonal and octagonal windows are not permitted.
- Mirrored glass shall not be used.

- Buildings shall have all openings trimmed in wood bands of minimum 4-inches nominal width unless approved based on design merit.
- Bay window projections shall be proportionate to the overall composition and are encouraged to extend to the ground or be trimmed appropriately. Cantilevered bays must be visually carried by structural brackets or a water table trim band. Only cantilevered bays may encroach into a setback.



- False shutters are not permitted.
- Canvas awnings are permitted and shall be square cut without side panels.

#### (h) Doors

- Exterior doors are encouraged to meet or exceed Energy Star standards as previously stated.
- Front doors shall be solid wood or have a wood appearance. Complimenting wood storm/screen doors are encouraged. High quality synthetic alternatives, such as fiberglass Masonite, may be considered based on detailing and proportions.



- Traditional sliding glass doors may only be used in yards facing open spaces and side yards.



- Garage doors shall be built of wood, steel, or fiberglass.



- Garage doors shall be de-emphasized in the elevation of the building. If possible, they should be oriented away from the street. If a lot does not have access to a woonerf and garage doors must face a street, the doors shall be made of a complementary and quality material and have significant detailing contributing to the elevation composition.
- To encourage varied massing, garage door wall planes fronting woonerfs must vary a minimum of 24” from adjacent attached wall planes.
- Detached garages and garage doors may front a woonerf if composed with overall site plan and have significant detailing contributing to the street elevation.



- Other more contemporary and creative approaches to garage doors will be considered based on design merit.



## (i) Roofs



- Asphalt composition shingles are permitted, but must be at least 30-year architectural grade.
- Treated wood shingles are permitted.
- Metal roof materials are a permitted but must be designed to protect people and property from significant sliding of snow and ice (not applicable to dormers or similar roof forms that do not drip directly to grade). Metal roofs may be corrugated or standing seam only. Unpainted, galvanized, rusted, brown, grey or rust-red-baked-on finish are all appropriate finishes. Garish colors or shiny materials are not appropriate.
- Natural or synthetic slate roof materials are permitted.
- Green roofs are encouraged.



- Flat roofs are permitted on all buildings if integrated with the design. Flat roofs used as balconies on street facades may be enclosed with solid railings.
- Roof plane continuous length dimensions shall not exceed 40' for single family and duplex structures and 100' for multifamily structures without a significant break. Minimum break shall be no less than 20% of the length roof plane and extend up the roof plane no less than 30% of the height of the roof.



**(j) Skylights**

- Skylights shall be flat in profile (no bubbles or domes).



**(k) Roof Mounted Solar Panels**

- Solar panels area encouraged for all projects.



**(l) Dormers**

- Dormer width shall be proportionate to the overall composition.



- Shed dormers shall have a pitch of at least 3:12. Hip and gable dormers shall have the same pitch as the main roof volume.

**(m) Eaves**

- Overhanging roof eave and gable end depth shall be no less than 24-inches unless approved otherwise based on design merit for a more contemporary style or flat roof. Roof overhang depth on accessory structures must match the main building structure.



- Fascia detail must have a minimum dimension of 8-inches nominal unless otherwise approved for design merit. Two-piece fascia detailing is required. Wood (including Miratec and similar products as determined by the Design Review Committee) is the only acceptable material. Vinyl or metal fascia material is not permitted. As an alternative, exposed rafter tails and entry accents are encouraged if appropriate for the architectural style.



- Soffits shall be wood (including Hardiboard products). Metal or vinyl soffits are not permitted.
- Boxed soffits are allowed when integrated into a suitable architectural style and overall detailing.



- Enclosed soffits are acceptable on more contemporary styles.



- Gutters shall be metal, and of a color and finish that blends with the finish color scheme. Gutters shall be half-round or rectangular and downspouts shall be circular or rectangular.

#### **(n) Chimneys / Roof Vents**



- Chimneys shall be clad in stone, masonry, siding, steel or some other compatible or complementary material.
- Chimneys shall be at least 30 x 30-inches.
- Prefabricated metal flues shall be concealed within a chimney unless approved otherwise. Chimney caps may extend above the chimney top per building code requirements.
- Roof protrusions, other than chimneys, shall be arranged to minimize street exposure.
- All roof-mounted equipment shall be integrated into overall design and screened.

**(o) Lighting**

- All exterior residential lighting must be dark—sky compliant.



All exterior lighting of all lots shall be limited to 800 lumens (12-watt LED bulbs/60-watt incandescent bulbs) and must be full cut-off and shielded bulb of such focus and intensity so as to not cause disturbance of adjacent lots.

- Recessed or can lighting is encouraged for porches and main entrances for softer lighting conditions.



- The following lighting is prohibited: obtrusive flood lighting, mercury vapor or high-pressure sodium lights, metal halide lights, and clear glass or exposed bulb (non-cutoff) fixtures.
- Pathway lighting is permitted. These types of lights may be attached to the home, along walkways near the ground level, or incorporated into fences. Solar powered lighting is strongly encouraged.
- Woonerfs will be lighted with the LED Cree Edge Series Pedestrian Pathway lighting or equivalent. Streets will be lighted with the LED KIM Archetype light fixtures or equivalent.
- 

**(p) Signage**

- No signs shall be erected on residential properties except to identify the owner and address of the property.
- Typical "For Sale" signs shall be allowed during the sale of a lot.
- Signage integrated with landscaping may be placed at the main entrances and parks to identify the neighborhood.

**6.3 Landscape**

The proper use of plant materials adds to a sense of permanence and consistency for a neighborhood while also connecting the built and natural environments. Landscape plans submitted with Form 3 should outline hardscape elements, fencing, and planting areas with species and quantities listed. Each Owner will be required to meet minimum landscape specifications related to two general categories: boulevard plantings and yard plantings.



### **(a) Street / Woonerf Boulevard Plantings**



- Individual Lot Owners shall be responsible for landscaping the boulevard area directly adjacent to their property at the time of occupancy and for the maintenance of the boulevard area thereafter.
- To enhance a public street boulevard where present, 1 tree (minimum 2½-inch diameter caliper) shall be planted per 50 feet in the boulevard area. Grass or an approved xeriscape plan must also be installed in the boulevard area directly adjacent to the subject property.
- To enhance a woonerf boulevard where present, 1 tree (minimum 2 ½-inch diameter caliper) shall be planted where utility conflicts do not exist as well as provide a composed planting bed that includes a minimum of 3 shrubs, perennial plantings and a minimum of 2 boulders. See Appendix D: Woonerf Diagram.
- Maximum height of landscaping in required vehicle vision triangles is 30-inches.
- It is the responsibility of the Owner to contact the appropriate utility companies before digging.

### **(b) Yard Plantings**

- All properties are required to landscape yards. Yards facing a street must be sod (fescue blend sod is strongly encouraged). Yards facing open space or side yards may be seeded.
- Native, drought tolerant grasses and regional plant materials are encouraged. Lawns should be well maintained, so they thrive and therefore, use fewer resources. Regular fertilizing (see below), aeration, and weekly cutting with a sharp blade are all critical to lawn success. Lawns should be maintained at about 4-inches as keeping lawns slightly long ensures the soil remains shaded, thereby using less water.

- Mulching, composting, efficient irrigation, harvesting water from roofs, sidewalks, driveways and other impervious surfaces are all encouraged.
- “Xeriscaping” or water-conserving, drought-tolerant landscaping is encouraged. A proposal for a Xeriscape landscape plan must be prepared by a landscape professional. United States Environmental Protection Agency (US EPA) has guidelines available at: <http://www.epa.gov/>.



- **Yards facing a street:**  
At least 1 tree (minimum 2½-inch caliper) and 2 appropriately sized planting beds are required for yards facing a public street. Corner lots are considered to have 2 separate yards and therefore require a total of 2 trees (minimum 2½-inch caliper) and 2 appropriately sized planting beds



- **Yards Facing a Woonerf:**  
At least 1 tree and 1 appropriately sized planting bed are required for yards facing a woonerf.
- **Yards Facing Open Spaces:**  
At least 1 tree (minimum 2½-inch diameter caliper) and 2 appropriately sized planting beds are required for any yard facing an open space.
- Planting beds must be composed with the site and the building elevations and shall have a top layer of mulch or earth tone stone (non-white).



- Maximum height of landscaping in required vehicle vision triangles is 30-inches.
- It is the responsibility of the Owner to contact the appropriate utility companies before digging.

**(c) Vegetation & Solar Gain**

- Special consideration should be given to areas of sun exposure and shade for the planting of trees and large shrubs. Landscaping should allow southern exposures necessary for a home's solar gain in the winter, or that of the neighbors.

**(d) Hardscapes**

- Selection of hardscape materials should favor natural materials such as untreated wood, stone, or stamped concrete, while balancing the desire for durability. Pressure treated lumber and railroad ties, although re-used, should be avoided for their toxicity.

**(e) Soil Preparation & Drainage**

- Investment at the soil level provides huge payoff in reduced water and fertilizer use, and plant vigor. Soils should be of the best quality available and improved with imported compost as feasible, especially in lawn areas. In areas where poor soils are unavoidable, homeowners should focus plant selection on species that thrive in such conditions. Runoff from roofs, and hardscapes, and melting snow, should be considered, and should be harvested for landscape use whenever possible.

**(f) Irrigation Systems & Water Use**

- Underground irrigation systems can use water efficiently, but they must be designed, installed and operated correctly. They also require regular maintenance.
- Plants with similar water usage, sun and shade requirements and zones with spray heads, rotors or drip systems should be grouped together.
- Plants should be sufficient in number and density to reduce weed growth. A weed mat also inhibits weed growth. Mulch conserves water and shades soil.
- Landscapes do not require as much water during shoulder seasons (May, June, September and October) as in July and August. Watering should be reduced in September and October to prepare vegetation for dormancy. Early morning is the

best time (4am-9am) to water because watering at night can encourage fungus and disease to grow. Avoid watering between 9am – 7pm.

- Water only when your turf requires it. If you leave distinct footprints when you step on it or the grass does not spring back, it is time to water. Applying one inch of water (including rainfall) each time you water once per week is enough to keep your lawn green throughout the summer.
- Turf grass should be watered using longer run times (15-20 minutes) but less often. This causes the grass roots to grow deeper thereby needing less water and becoming more drought and weed resistant. Frequent watering of turf grass causes the root base to remain shallow causing the grass to brown easily and it will be more susceptible to drought and weeds.
- When watering trees and shrubs it is not necessary to water the leaves or the trunk. Instead, place a sufficient number of emitters evenly around the tree or shrub halfway between the trunk and the outer canopy.

#### **(g) Fertilizing / Pesticides**

- In careful consideration of the lakes and streams, homeowners that border open spaces or parks with surface water (lakes, streams, wetlands) will only be permitted to use non-chemical fertilizers / pesticides in required yard setbacks. Organic fertilizers for lawns are readily available, as are corn based weed suppression substitutes. Non-lawn native and drought tolerant plantings typically require no extra fertilizing at all.

#### **(h) Weed control**

- As further specified in the covenants, noxious weeds pose a serious threat to the environment, and property owners should familiarize themselves with, and control them, on their property. Chemical solutions should be balanced with the threat level of the individual species and the possibility for non-chemical alternative treatments. Under no circumstance should noxious weeds be allowed to flourish or go past the flowering stage and into the seed stage. Weed control is required on both developed and vacant lots and will be enforced in accordance with the Covenants.

#### **(i) Vegetation Removal**

- No landscaping in the right-of-way, parks, open spaces and common areas may be removed without prior permission from the DRP.

### **6.4 Variances from Neighborhood Patterns**

The DRP encourages unique and creative design that respects the spirit and intent of the Declaration and Design Manual. Except as otherwise set forth in Chapter 3, the DRP may, upon application, grant a variance from the Design Manual, based on design merit.

The Board of Directors shall have the power to make the final decision on whether to approve, conditionally approve, or deny a variance, without any liability being incurred or damages being assessed due to any decision of the Board of Directors.



# Chapter **7** : Amendments

Amendments to Design Manual may only be made as set forth in the Declaration.

Any amendments to the Design Manual will be posted on the Valley West Homeowners Association website.

A submittal shall be processed consistent with the Design Manual in effect 30 days prior to DRP receipt of a complete Form 2 submittal.

No improvements that were constructed and approved in accordance with the Design Manual shall be required to be changed because such standards are thereafter amended.

## **Amendments & clarifications since initial design manual:**

### **7.1 FAR (Floor Area Ratio)**

The FAR requirements are a new addition to the revised UDC that went into effect on April 1, 2018. These standards did not exist under the previous UDC that Phases 4, 5 & 6 of The Lakes were reviewed and evaluated under. The Lakes at Valley West is a unique development that incorporates aspects of other zoning districts to attain the quality and features of the neighborhood. The Lakes at Valley West utilize the design guidelines and covenants and restrictions to protect the development and design integrity that maximum FARs provide. The Lakes at Valley West presented this information to City Planning on June 12, 2018 and was granted a minor amendment to waive the FAR requirement for Phases 4, 5 & 6. In a letter dated August 16, 2018 City staff advised that waiving the FAR requirement be applied to all phases (*Sec. 3.C of Appendices A1-A4*).

### **7.2 Yards**

Updated language regarding yards and porch encroachments now applies to all phases (*Sec. 5.B.2 of Appendices A1-A4*). Additional language regarding porch encroachments into yards has been added.

### **7.3 Residential Garages**

Clarification: Residential garages are only required to meet two or more of the criteria described to be subordinate to the dwelling (*Sec. 7.A of Appendices A1-A4*).

All amendments are outlined in Appendices A1, A2, A3, and A4 of this document that detail PUD zoning districts. See Appendix G for an approval letter from the City regarding these modifications.

## Chapter **8**: Definitions

The words and terms used in this document shall have their customary dictionary definitions unless otherwise specifically defined within the Declaration or this Design Manual.

**Exhibit 1**  
**The Lakes at Valley West, Phases 1 & 2 Subdivision Legal Description**

Tract 1 of Certificate of Survey No. 1005B, and Tract 2A of Certificate of Survey No. 1005C, hereinafter known as "The Lakes at Valley West Subdivision – Phase 1 and Phase 2", situated in the NE ¼ NW ¼ and NW ¼ NE ¼ of Section 9, Township 2 South, Range 5 East, Principal Meridian, City of Bozeman, Gallatin County, Montana, more particularly described as follows:

Commencing at the Corner to Sections 4, 5, 8, and 9, Township 2 South, Range 5 East, Principal Meridian, as described on Certified Corner Recordation, Book 2, Page 1572, Document No. 380638, filed at the Gallatin County Clerk and Recorder's Office; thence N.89° 32' 48"E. for 1337.30 feet to the West One-sixteenth Corner between Section 4 and Section 9, being the northwest corner of Tract 1 of Certificate of Survey No. 1005B, the Point of Beginning; thence continuing N.89° 32' 48"E. for 1337.30 feet to the One-quarter Corner between Section 4 and Section 9, being the north corner common to Tract 1 of Certificate of Survey No. 1005B and Tract 2A of Certificate of Survey No. 1005C; thence S.88° 44' 32"E. for 826.90 feet to the north corner common to Tract 2A and Tract 3A of Certificate of Survey No. 1005C, from which the Corner to Sections 3, 4, 9, and 10, as described on Certified Corner Recordation, Book 2, Page 1577, Document No. 380643, filed at the Gallatin County Clerk and Recorder's Office, bears S.88° 44' 32"E., 1816.88 feet distant; thence S.02° 30' 35"W. for 659.22 feet to an angle point between Tract 2A and Tract 3A of Certificate of Survey No. 1005C; thence S.26° 04' 23"W. for 437.25 feet to an angle point between Tract 2A and Tract 3A of Certificate of Survey No. 1005C; thence S.02° 30' 35"W. for 289.84 feet to the south corner common to Tract 2A and Tract 3A of Certificate of Survey No. 1005C, being a point on the north line of SW ¼ NE ¼ of said Section 9; thence N.89° 11' 53"W. for 650.69 feet to the Center-North One-sixteenth Corner of said Section 9, being the south corner common to Tract 1 of Certificate of Survey No. 1005B and Tract 2A of Certificate of Survey No. 1005C; thence S.89° 56' 46"W. for 1337.16 feet to the Northwest One-sixteenth Corner of said Section 9, being the south corner common to Tract 1 of Certificate of Survey No. 1005B and Tract 2 of Certificate of Survey No. 1581; thence N.02° 27' 30"E. for 1341.86 feet to the West One-sixteenth Corner between Section 4 and Section 9, the Point of Beginning.

The Area of the above described tracts of land is 64.89 Acres, more or less.

**Exhibit 2**  
**The Lakes at Valley West, Phase 3 Subdivision Legal Description**

Phase 3 of The Lakes at Valley West, being a portion of Lot R2 of The Lakes at Valley West – Phase 1 & Phase 2, Plat J-572; situated in the NE $\frac{1}{4}$ NW $\frac{1}{4}$  of Section 9, Township 2 South, Range 5 East, Principal Meridian, City of Bozeman, Gallatin County, Montana, more particularly described as follows:

Commencing at the Corner to Sections 4, 5, 8, and 9, Township 2 South, Range 5 East, Principal Meridian, as described on Certified Corner Recordation, Book 2, Page 1572, Document No. 380638, filed at the Gallatin County Clerk and Recorder's Office; thence N.88° 04' 19"E. for 1337.30 feet to the West One-sixteenth Corner between Section 4 and Section 9; thence S.00° 59' 02"W. for 50.06 feet along the east boundary of the NW $\frac{1}{4}$ NW $\frac{1}{4}$  of Section 9 to a point on the south right-of-way of Durston Road, the Point of Beginning; thence N.88° 04' 19"E. for 873.66 feet along the south right-of-way of Durston Road to the northwest corner of Phase 2 of The Lakes at Valley West; thence S.1°54'25"E., 25.00 feet to an angle point on the west boundary of Phase 2 of The Lakes at Valley West; thence S.19°42'50"W., 388.15 feet to an angle point on the west boundary of Phase 2 of The Lakes at Valley West; thence S.13°17'40"E., 223.76 feet to the southwest corner of Phase 2 of The Lakes at Valley West; thence S.88°04'19"W., 296.79 feet to a point; thence along a curve to the left, having a radius of 280.00 feet, a central angle of 24°45'39", an arc length of 121.00 feet to a point, the chord being N.24°09'14"W., 120.06 feet; thence N.36°32'03"W., 62.13 feet to a point; thence S.50°56'59"W., 90.09 feet to a point; thence S.53°42'03"W., 60.00 feet to a point; thence S.56°35'13"W., 64.64 feet to a point; thence S.63°07'43"W., 86.94 feet to a point; thence S.75°16'23"W., 33.24 feet to a point thence S.84°04'23"W., 52.71 feet to a point; thence N.89°04'37"W., 87.84 feet to a point on the east boundary of the NW $\frac{1}{4}$ NW $\frac{1}{4}$  of Section 9; thence N.0°59'02"E., 609.00 feet to the Point of Beginning.

The Area of the above described tracts of land is 459,420 Square Feet, or 10.547 Acres, more or less.

### Exhibit 3

#### The Lakes at Valley West, Phase 4 Subdivision Legal Description

**Phase 4 of The Lakes at Valley West**, being a portion of Lot R2A of The Lakes at Valley West – Phase 3, Plat J-598; situated in the NE $\frac{1}{4}$ NW $\frac{1}{4}$  of Section 9, Township 2 South, Range 5 East, Principal Meridian, City of Bozeman, Gallatin County, Montana, more particularly described as follows:

Commencing at the Corner to Sections 4, 5, 8, and 9, Township 2 South, Range 5 East, Principal Meridian, as described on Certified Corner Recordation, Book 4, Page 931, Document No. 2566976, filed at the Gallatin County Clerk and Recorder's Office; thence N.88° 04' 19"E., 1337.30 feet to the West One-sixteenth Corner between Section 4 and Section 9; thence S.00° 59' 02"W., 659.06 feet along the east boundary of the NW $\frac{1}{4}$ NW $\frac{1}{4}$  of Section 9 to the southwest corner of Phase 3 of The Lakes at Valley West, **the Point of Beginning**; thence along the south boundary of Phase 3 of The Lakes at Valley West S.89° 00' 58"E., 82.84 feet; thence continuing along said boundary N.84°34'24"E., 57.69 feet; thence N.75°16'23"E., 33.24 feet; thence N.63°07'43"E., 86.94 feet; thence N.56°35'13"E., 64.64 feet; thence N.53°42'03"E., 60.00 feet; thence N.50°56'59"E., 90.09 feet to an angle point on the south boundary of Phase 3 of The Lakes at Valley West; thence continuing along said boundary S.36°32'03"E., 62.13 feet to a point of curvature; thence along a curve to the right having a radius of 280.00 feet, a central angle of 24°45'39" for an arc length of 121.00 feet to an angle point on the south boundary of Phase 3 of The Lakes at Valley West; thence N.88°04'19"E., 783.80 feet to the southeast corner of Phase 2 of The Lakes at Valley West a common point on the west right-of-way of North Laurel Parkway; thence S.0°58'16"W., 329.51 feet to a point on the west right-of-way of North Laurel Parkway; thence S.88° 28' 17"W., 727.53 feet; thence along a curve to the left having a radius of 20.00 feet, a central angle of 87°29'16" for an arc length of 30.54 feet, a chord bearing of S.44°43'39"W for a length of 27.66 feet; thence S.00°59'02"W., 12.34 feet; thence N.89°00'58"W., 120.00 feet; thence S.0°59'02"W., 31.41 feet; thence N.89°00'58"W., 60.00 feet; thence N.0°59'02"E., 24.00 feet; thence N.89°00'58"W., 364.84 feet to a point on the east boundary of the NW $\frac{1}{4}$ NW $\frac{1}{4}$  of Section 9; thence N.0°59'02"E., 332.42 feet along the east boundary of the NW $\frac{1}{4}$ NW $\frac{1}{4}$  of Section 9 to **the Point of Beginning**.

The Area of the above described tracts of land is 461,024 Square Feet, or 10.584 Acres, more or less.

## **Exhibit 4**

### **The Lakes at Valley West, Phase 5 & Phase 6 Subdivision Legal Description**

#### **Phase 5**

The Lakes at Valley West - **Phase 5**, being Lot R2B of The Lakes at Valley West - Phase 4; situated in the NE $\frac{1}{4}$ NW $\frac{1}{4}$  of Section 9, Township 2 South, Range 5 East, Principal Meridian, City of Bozeman, Gallatin County, Montana, more particularly described as follows:

Commencing at the Quarter Corner to Sections 4 and 9, Township 2 South, Range 5 East, Principal Meridian, City of Bozeman, Gallatin County, Montana, as described on Certified Corner Recordation, Book 4, Page 930, Document No. 2566975, filed at the Gallatin County Clerk and Recorder's Office; thence S.0°58'16"W. for 1351.17 feet to the CN 1/16 Corner of said Section 9; thence S.88°28'17"W. for 45.04 feet to the Point of Beginning Phase 5; thence S.88°28'17"W. for 1292.11 feet to the the NW 1/16 Corner of said Section 9, also being the Southwest Corner of The Lakes at Valley West Subdivision; thence N.00°59'02"E. for 350.37 feet to the Southwest Corner of Phase 4 of The Lakes at Valley West Subdivision; thence continuing along the south boundary of Phase 4 of said subdivision for the next eight courses; S.89°00'58"E. for 364.84 feet; thence S.0°59'02"W. for 24.00 feet; thence S.89°00'58"E. for 60.00 feet; thence N.0°59'02"E. for 31.41 feet; thence S.89°00'58"E. for 120.00 feet; thence N.0°59'02"E. for 12.34 feet; thence along a curve to the right having a radius of 20 feet and a central angel of 87°29'15" along said curve for an arc length of 30.54 feet; thence N.88°28'17"E. for 727.53 feet to the west right-of-way line of Laurel Parkway; thence along said right-of-way line S.0°58'16"W. for 365.35 feet to the Point of Beginning Phase 5.

The Area of the above described tracts of land is 456,302 Square Feet, or 10.475 Acres, more or less.

#### **Phase 6**

The Lakes at Valley West - **Phase 6**, being Lot R1 of The Lakes at Valley West - Phase 1 & Phase 2; situated in the NW $\frac{1}{4}$ NE $\frac{1}{4}$  of Section 9, Township 2 South, Range 5 East, Principal Meridian, City of Bozeman, Gallatin County, Montana, more particularly described as follows:

Commencing at the Quarter Corner to Sections 4 and 9, Township 2 South, Range 5 East, Principal Meridian, City of Bozeman, Gallatin County, Montana, as described on Certified Corner Recordation, Book 4, Page 930, Document No. 2566975, filed at the Gallatin County Clerk and Recorder's Office; thence S.0°58'16"W. for 1351.17 feet, to the CN 1/16 Corner of said Section 9, thence N.89°19'38"E. for 45.02 feet to the Point of Beginning Phase 6; thence N.0°58'16"E. for 691.60 feet to the Southwest Corner of Phase 1 of The Lakes at Valley West, thence N.89°46'55"E. for 781.15 feet to the Southeast Corner of Phase 1 of The Lakes at Valley West, thence S.24°35'54"W. for 437.25 feet, thence S.1°02'06"W. for 289.84' feet to the north boundary of Lot R1 of Norton East Ranch Subdivision Phase 3A, thence S.89° 19' 38"W. for 605.66 feet to the Point of Beginning Phase 6.

The Area of the above described tracts of land is 452,218 square feet, or 10.381 acres, more or less.

## **Appendix A1**

### **ARTICLE 8 - PUD1 – THE LAKES AT VALLEY WEST PLANNED UNIT DEVELOPMENT (PUD) ZONING DISTRICT Phases 1 & 2**

#### **Sec. 1 - Intent and purpose.**

A. The intent and purpose of the Lakes at Valley West Planned Unit Development (PUD) Residential Zoning District is to set forth certain standards for development within the PUD that vary from the Unified Development Code (UDC) typical residential zoning districts. Other relaxations from the UDC are detailed in the PUD application and are related to subdivision design. This District applies to all lots within The Lakes at Valley West. Future changes to the R-1 zone in UDC do not impact the subject properties.

1. The intent of the Lakes at Valley West residential density district is to provide for a variety of small lots for lower intensity single, two and three household residential development and related uses (including accessory dwelling units) within the city at urban densities in a master planned area and to provide for such community facilities and services as will serve the area's residents while respecting the residential character and quality of the area. It should provide for a variety of housing types to serve the varied needs of households of different size, age and character.

2. In exchange for relaxations, strict design standards have been established in The Lakes at Valley West Design Manual which is administered by The Lakes at Valley West Design Review Panel. Many of these standards are more stringent than the requirements of the UDC.

#### **Sec. 2 - Authorized uses.**

A. Uses are depicted in the table below. Appendix C in the Design Manual designates which lots are allowed which uses. Principal uses are indicated with a "P", conditional uses are indicated with a "C", accessory uses are indicated with an "A" and uses which are not permitted with the district are indicated by a "-". "C" uses require a Conditional Use Permit from the City of Bozeman but must receive approval from The Lakes at Valley West Design Review Panel prior to submitting any applications to the City.

B. Note that additional uses for telecommunication uses are contained in the UDC.

C. The uses listed are deliberately broad and some are given special definitions in the UDC. The intent of this method is to provide general guidance for uses while allowing the unique needs and circumstances of each proposal to be specifically addressed through the review process. Some uses are the subject of special regulations contained in the UDC.



<b>Table of Residential Uses for The Lakes at Valley West PUD</b>	<b>Type of Use</b>
Accessory dwelling units <sup>1</sup>	P (only on specifically designated lots in Appendix C)
Community centers	C
Community residential facilities with eight or fewer	P
Cooperative housing	C
Day care centers	C
Essential services Type I	A
Essential services Type II	P
Essential services Type III	C
Family day care home	P
Fences	A
Greenhouses	A
Group day care home	C
Group living <sup>2</sup>	P
Guesthouses	A
Home-based businesses <sup>3</sup>	A/C
Other buildings and structures typically accessory to	A
Private garages	A
Private or jointly owned recreational facilities	A
Private stormwater control facilities	A
Public and private parks and park improvements	P
Manufactured homes on permanent foundations <sup>4</sup>	P
Single-household dwelling	P
Temporary buildings and yards incidental to	A
Temporary sales and office buildings	A
Three-household dwelling	P (only on specifically designated lots in Appendix C)
Two-household dwelling	P (only on specifically designated lots in Appendix C)
“Limited Two Household/Duplex” <sup>5</sup>	P (only on specifically designated lots in Appendix C)
Townhouses (two or three attached townhomes)	P (only on specifically designated lots in Appendix C)
Tool sheds for storage of domestic supplies	A
Uses approved as part of the Lakes at Valley West	P

Notes:

<sup>1</sup> Only one ADU per designated lot in Appendix C; one separated off-street parking space required for the second unit; occupancy may not exceed two persons or one bedroom; living area limited to 600 SF.

<sup>2</sup> Group living is subject to the requirements of the UDC.

<sup>3</sup> Home-based businesses are subject to the terms and thresholds of the UDC.

<sup>4</sup> Manufactured homes are subject to the standards of the UDC and must adhere to the architectural standards established by The Lakes at Valley West Design Manual.

<sup>5</sup> “Limited Two Household/Duplexes” (similar to attached ADUs) are allowed on designated lots in Appendix C; one separated off-street parking space is required for the second unit; occupancy may not exceed three persons or two bedrooms; living area is limited to one-third of the total square footage of the main residence.

**Sec. 3 - Lot coverage and floor area.**

- A. Maximum lot coverage by principal and accessory buildings shall be:
  - 1. Not more than 50 percent of the lot area
- B. Minimum floor area requirements for each dwelling in all districts shall be that area required by the city's adopted International Building Code.
- C. There are no FAR (floor area ratio) requirements for Phases 1 & 2.

**Sec. 4 - Lot area and width.**

- A. All lots shall have a minimum area as set forth in the table below and are cumulative. These minimums assume a lack of development constraints.

<b>Table of Minimum Lot Areas for The Lakes at Valley West PUD</b>	<b>Minimum Lot Area (SF)</b>
Single-household dwelling	2,500
Two-household dwelling (including "limited two-household/duplex")	3,000
Three-household dwelling	4,000
Lot area <i>per townhouse</i> (including duplex townhomes and triplex townhomes)	2,500 (2,000 for interior unit)
Additional area required for a detached accessory dwelling unit	none
All other uses	5,000

- B. All lots shall have a minimum width as set forth in the table below. These minimums assume a lack of development constraints.

<b>Table of Minimum Lot Widths for The Lakes at Valley West PUD</b>	<b>Minimum Lot Width</b>
Single-household dwelling	25
Two-household dwelling	25
Accessory dwelling unit	none
Dwellings in three-household dwelling configurations	25
Townhouses	25
All other uses	50

**Sec. 5 - Yards.**

A. Minimum yards required are:

1. Any yard facing a street: 15 feet; 20 feet for garage doors
2. Any yard facing a Woonerf: 15 feet; See Appendix C1 for garage door setbacks.
3. Any yard facing open space: 10-20 feet (see Lot Exhibits in Appendix C1)
3. Any side yard: 5-12 feet; or zero feet for interior walls of townhouses (see Lot Exhibits in Appendix C1)

B. Yard Encroachments:

1. Decks and patios must face only side yards and/or open spaces. Decks and patios may not extend more than 40 percent feet into any required side setback.
2. Porches may encroach up to 5 feet into a 15’ yard setback facing a street or 15’ yard facing a Woonerf only if all four of the following conditions are met:
  - i. The encroaching porch must have a length equal to or greater than one-half the length of the building façade or 12 feet, whichever is greater. The remaining portion may be occupied by an integrated façade as defined in this Design Manual:
  - ii. The encroaching porch must have a minimum depth of six (6) feet;
  - iii. Second or subsequent stories are not allowed to encroach into the 15-foot street or Woonerf facing yard; and
  - iv. No stairs are permitted beyond the 10-foot setback.

Side Setback	Deck/Patio Encroachment
5’	2’
7’	2’-9”
12’	4’-9”

**Sec. 6 - Building height.**

Maximum building height for each residential district shall be as follows:

Table of Heights for The Lakes at Valley West	Height (in feet)
Less than 3:12	34
3:12 or greater but less than 6:12	38
6:12 or greater but less than 9:12	42

**Sec. 7 - Residential garages.**

- A. Attached residential garages facing a street shall not obscure the entrance to the dwelling. Attached garages are required to be clearly subordinate to the dwelling. A subordinate garage **has two or more** of the following characteristics:
1. The principal facade of the dwelling is emphasized with architectural features such as, but not limited to, porches, fenestration treatment, architectural details, height, orientation or gables, so that the non-garage portion of the residence is visually dominant;
  2. The facade with the garage vehicle entrance is recessed at least four feet behind the facade of the dwelling containing the main entry; **and/or**
  3. The area of the garage vehicle door comprises 30 percent or less of the total square footage, exclusive of any exposed roof areas, of the principal facade of the dwelling. Principal facade shall include all wall areas parallel to the garage door.
- B. Residential garages facing a woonerf are not required to meet the above criteria.

**Sec. 8 – Parking**

- A. Parking requirements in terms of the number and size of spaces are the same as the most current version of the UDC.
- B. Where a woonerf serves lots, access to garages and off-street parking shall be off the woonerf. In cases where a woonerf is not adjacent to a lot, accesses to garages are permitted to be off the street.
- C. Driveways are encouraged to be shared wherever possible to minimize street cuts and maximize on-street parking options.
- D. All “required” parking spaces must meet the minimum dimensions established in the UDC.
- E. Parking spaces shall not block sidewalks, woonerfs, driveways, accesses, pedestrian facilities or snow removal/plowing.
- F. The developer will provide parallel parking spaces along the woonerf in several designated locations. Driveways must be located outside of these parking areas.

**Sec. 9 - Minimum density.**

- A. New residential development shall provide a minimum net density of five dwellings per net acre. A minimum is required to support efficiency in use of land and provision of municipal services, and to advance the purposes and goals of this chapter and the City’s

adopted growth policy. Density may be achieved by averaging lot sizes over the entire Lakes at Valley West PUD area. For example, one phase or area may be less than five units per net acre while another may be greater than five units per net acre if as the average is at least five units per net acre.

### **Sec. 10 – Architectural, Additional Site and Landscape Requirements**

- A. The Lakes at Valley West Design Manual includes additional site, architectural and landscape requirements that are all subject to review and approval by The Lakes at Valley West Design Review Panel. Appendix C1 of the Design Manual contains detailed lot exhibits that provide specific information per lot regarding uses, setbacks, etc.

## **Appendix A2**

### **ARTICLE 8 - PUD1 –THE LAKES AT VALLEY WEST PLANNED UNIT DEVELOPMENT (PUD) ZONING DISTRICT PHASE 3**

#### **Sec. 1 - Intent and purpose.**

A. The intent and purpose of the Lakes at Valley West Planned Unit Development (PUD) Phase 3 Residential Zoning District is to set forth certain standards for development within the PUD that vary from the Unified Development Code (UDC) typical residential zoning districts. Other relaxations from the UDC are detailed in the PUD application and are related to subdivision design. This District applies to all lots within The Lakes at Valley West. Future changes to the R-1 zone in UDC do not impact the subject properties.

1. The intent of the Lakes at Valley West residential density district is to provide for a variety of small lots for lower intensity single, two household residential development and related uses (including accessory dwelling units) within the city at urban densities in a master planned area and to provide for such community facilities and services as will serve the area's residents while respecting the residential character and quality of the area. It should provide for a variety of housing types to serve the varied needs of households of different size, age and character.

2. In exchange for relaxations, strict design standards have been established in The Lakes at Valley West Design Manual which is administered by The Lakes at Valley West Design Review Panel. Many of these standards are more stringent than the requirements of the UDC.

#### **Sec. 2 - Authorized uses.**

A. Uses are depicted in the table below. Appendix C in the Design Manual designates which lots are allowed which uses. Principal uses are indicated with a "P", conditional uses are indicated with a "C", accessory uses are indicated with an "A" and uses which are not permitted with the district are indicated by a "-". "C" uses require a Conditional Use Permit from the City of Bozeman but must receive approval from The Lakes at Valley West Design Review Panel prior to submitting any applications to the City.

B. Note that additional uses for telecommunication uses are contained in the UDC.

C. The uses listed are deliberately broad and some are given special definitions in the UDC. The intent of this method is to provide general guidance for uses while allowing the unique needs and circumstances of each proposal to be specifically addressed through the review process. Some uses are the subject of special regulations contained in the UDC.

<b>Table of Residential Uses for The Lakes at Valley West PUD- Phase 3</b>	<b>Type of Use</b>
Accessory dwelling units <sup>1</sup>	P (only on specifically designated lots in Appendix C)
Community centers	C
Community residential facilities with eight or fewer	P
Cooperative housing	C
Day care centers	C
Essential services Type I	A
Essential services Type II	P
Essential services Type III	C
Family day care home	P
Fences	A
Greenhouses	A
Group day care home	C
Group living <sup>2</sup>	P
Guesthouses	A
Home-based businesses <sup>3</sup>	A/C
Other buildings and structures typically accessory to	A
Private garages	A
Private or jointly owned recreational facilities	A
Private stormwater control facilities	A
Public and private parks and park improvements	P
Manufactured homes on permanent foundations <sup>4</sup>	P
Single-household dwelling	P
Temporary buildings and yards incidental to	A
Temporary sales and office buildings	A
Two-household dwelling	P (only on specifically designated lots in Appendix C)
“Limited Two Household/Duplex” <sup>5</sup>	P (only on specifically designated lots in Appendix C)
Townhouses (two or three attached townhomes)	P (only on specifically designated lots in Appendix C)
Tool sheds for storage of domestic supplies	A
Uses approved as part of the Lakes at Valley West	P

Notes:

<sup>1</sup> Only one ADU per designated lot in Appendix C; one separated off-street parking space required for the second unit; occupancy may not exceed two persons or one bedroom; living area limited to 600 SF.

<sup>2</sup> Group living is subject to the requirements of the UDC.

<sup>3</sup> Home-based businesses are subject to the terms and thresholds of the UDC.

<sup>4</sup> Manufactured homes are subject to the standards of the UDC and must adhere to the architectural standards established by The Lakes at Valley West Design Manual.

<sup>5</sup> “Limited Two Household/Duplexes” (similar to attached ADUs) are allowed on designated lots in Appendix C; one separated off-street parking space is required for the second unit; occupancy may not exceed three persons or two bedrooms; living area is limited to one-third of the total square footage of the main residence.



**Sec. 3 - Lot coverage and floor area.**

- A. Maximum lot coverage by principal and accessory buildings shall be:
  - 1. Not more than 50 percent of the lot area
- B. Minimum floor area requirements for each dwelling in all districts shall be that area required by the city's adopted International Building Code.
- C. There are no FAR (floor area ratio) requirements for Phase 3.

**Sec. 4 - Lot area and width.**

- A. All lots shall have a minimum area as set forth in the table below and are cumulative. These minimums assume a lack of development constraints.

Table of Minimum Lot Areas for The Lakes at Valley West PUD	Minimum Lot Area (SF)
Single-household dwelling	2,500
Two-household dwelling (including "limited two-household/duplex")	3,000
Lot area <i>per townhouse</i> (including duplex townhomes and triplex townhomes)	2,400 (2,000 for interior unit)
Additional area required for a detached accessory dwelling unit	none
All other uses	5,000

- B. All lots shall have a minimum width as set forth in the table below. These minimums assume a lack of development constraints.

Table of Minimum Lot Widths for The Lakes at Valley West PUD	Minimum Lot Width
Single-household dwelling	25
Two-household dwelling	25
Accessory dwelling unit	none
Dwellings in three-household dwelling configurations	25
Townhouses	25
All other uses	50

**Sec. 5 - Yards.**

- A. Minimum yards required are:
  - 1. Any yard facing a street: 15 feet; 20 feet for garage doors
  - 2. Any yard facing a Woonerf: 15 feet; See Appendix C2 for garage door setbacks.
  - 3. Any yard facing open space: 5-20 feet (see Lot Exhibits in Appendix C2)

3. Any side yard: 5-12 feet; or zero feet for interior walls of townhouses (see Lot Exhibits in Appendix C2)

**B. Yard Encroachments:**

1. Side yards and/or Open Space yards.
  - a. Decks and patios must face only side yards and/or open spaces. Decks and patios may not extend more than 40 percent feet into any required side setback.

Setback	Deck/Patio Encroachment
5'	2'
7'	2'-9"
10'	4'
12'	4'-9"

- b. For Lots 1-6; 25-28; and 58-61 only, first and second floor porches fronting Durston Road may encroach up to 5 feet into a 10' open space setback only if the covered deck exceeds 1/3 in length of the building.
2. Porches may encroach up to 5 feet into a 15' yard setback facing a street or 15' yard facing a Woonerf only if all four of the following conditions are met:
  - v. The encroaching porch must have a length equal to or greater than one-half the length of the building façade or 12 feet, whichever is greater. The remaining portion may be occupied by an integrated façade as defined in this Design Manual:
  - vi. The encroaching porch must have a minimum depth of six (6) feet;
  - vii. Second or subsequent stories are not allowed to encroach into the 15-foot street or Woonerf facing yard; and
  - viii. No stairs are permitted beyond the 10-foot setback.

**Sec. 6 - Building height.**

Maximum building height for each residential district shall be as follows:

Table of Heights for The Lakes at Valley West	Height (in feet)
Less than 3:12	34
3:12 or greater but less than 6:12	38
6:12 or greater but less than 9:12	42
Equal to or greater than 9:12	44

## **Sec. 7 - Residential garages.**

- A. Attached residential garages facing a street shall not obscure the entrance to the dwelling. Attached garages are required to be clearly subordinate to the dwelling. A subordinate garage **has two or more** of the following characteristics:
1. The principal facade of the dwelling is emphasized by using architectural features such as, but not limited to, porches, fenestration treatment, architectural details, height, orientation or gables, so that the non-garage portion of the residence is visually dominant;
  2. The facade with the garage vehicle entrance is recessed at least four feet behind the facade of the dwelling containing the main entry; **and/or**
  3. The area of the garage vehicle door comprises 30 percent or less of the total square footage, exclusive of any exposed roof areas, of the principal facade of the dwelling. Principal facade shall include all wall areas parallel to the garage door.
- B. Residential garages facing a woonerf are not required to meet the above criteria.

## **Sec. 8 – Parking**

- A. Street-accessed and woonerf-accessed driveways shall be of concrete, or built of brick or concrete pavers approved in advance by the DRP. Woonerf-accessed driveways may also be paved with asphalt, when approved, as an extension of the paved alley.
- B. Parking requirements in terms of the number and size of spaces are the same as the most current version of the UDC.
- C. Where a woonerf serves lots, access to garages and off-street parking shall be off the woonerf. In cases where a woonerf is not adjacent to a lot, accesses to garages are permitted to be off street.
- D. Driveways are encouraged to be shared wherever possible to minimize street cuts and maximize on-street parking options.
- E. All “required” parking spaces must meet the minimum dimensions established in the UDC.
- F. Parking spaces shall not block sidewalks, woonerfs, driveways, accesses, pedestrian facilities or snow removal/plowing.
- G. The developer will provide parking spaces along the woonerf in several designated locations. Driveways must be located outside of these parking areas.

## **Sec. 9 - Minimum density.**

- A. New residential development shall provide a minimum net density of five dwellings per net acre. A minimum is required to support efficiency in use of land and provision of municipal services, and to advance the purposes and goals of this chapter and the City’s

adopted growth policy. Density may be achieved by averaging lot sizes over the entire Lakes at Valley West PUD area. For example, one phase or area may be less than five units per net acre while another may be greater than five units per net acre as long as the average is at least five units per net acre.

## **Sec. 10 – Architectural, Additional Site and Landscape Requirements**

- A. The Lakes at Valley West Design Manual includes additional site, architectural and landscape requirements that are all subject to review and approval by The Lakes at Valley West Design Review Panel. Appendix C2 of the Design Manual contains detailed lot exhibits that provide specific information per lot regarding uses, setbacks, etc.

## **Appendix A3**

### **ARTICLE 8 - PUD1 –THE LAKES AT VALLEY WEST PLANNED UNIT DEVELOPMENT (PUD) ZONING DISTRICT PHASE 4**

#### **Sec. 1 - Intent and purpose.**

A. The intent and purpose of the Lakes at Valley West Planned Unit Development (PUD) Phase 4 Residential Zoning District is to set forth certain standards for development within the PUD that vary from the Unified Development Code (UDC) typical residential zoning districts. Other relaxations from the UDC are detailed in the PUD application and are related to subdivision design. This District applies to all lots within The Lakes at Valley West. Future changes to the R-1 zone in UDC do not impact the subject properties.

1. The intent of the Lakes at Valley West residential density district is to provide for a variety of small lots for lower intensity single, two household residential development and related uses (including accessory dwelling units) within the city at urban densities in a master planned area and to provide for such community facilities and services as will serve the area's residents while respecting the residential character and quality of the area. It should provide for a variety of housing types to serve the varied needs of households of different size, age and character.

2. In exchange for relaxations, strict design standards have been established in The Lakes at Valley West Design Manual which is administered by The Lakes at Valley West Design Review Panel. Many of these standards are more stringent than the requirements of the UDC.

#### **Sec. 2 - Authorized uses.**

A. Uses are depicted in the table below. Appendix C in the Design Manual designates which lots are allowed which uses. Principal uses are indicated with a "P," conditional uses are indicated with a "C," accessory uses are indicated with an "A" and uses which are not permitted with the district are indicated by a "-." "C" uses require a Conditional Use Permit from the City of Bozeman but must receive approval from The Lakes at Valley West Design Review Panel prior to submitting any applications to the City.

B. Note that additional uses for telecommunication uses are contained in the UDC.

C. The uses listed are deliberately broad and some are given special definitions in the UDC. The intent of this method is to provide general guidance for uses while allowing the unique needs and circumstances of each proposal to be specifically addressed through the review process. Some uses are the subject of special regulations contained in the UDC.

<b>Table of Residential Uses for The Lakes at Valley West PUD- Phase 4</b>	<b>Type of Use</b>
Accessory dwelling units <sup>1</sup>	P (only on specifically designated lots in Appendix C)
Community centers	C
Community residential facilities with eight or fewer	P
Cooperative housing	C
Day care centers	C
Essential services Type I	A
Essential services Type II	P
Essential services Type III	C
Family day care home	P
Fences	A
Greenhouses	A
Group day care home	C
Group living <sup>2</sup>	P
Guesthouses	A
Home-based businesses <sup>3</sup>	A/C
Other buildings and structures typically accessory to	A
Private garages	A
Private or jointly owned recreational facilities	A
Private stormwater control facilities	A
Public and private parks and park improvements	P
Manufactured homes on permanent foundations <sup>4</sup>	P
Single-household dwelling	P
Temporary buildings and yards incidental to	A
Temporary sales and office buildings	A
Two-household dwelling	P (only on specifically designated lots in Appendix C)
“Limited Two Household/Duplex” <sup>5</sup>	P (only on specifically designated lots in Appendix C)
Townhouses (two or three attached townhomes)	P (only on specifically designated lots in Appendix C)
Tool sheds for storage of domestic supplies	A
Uses approved as part of the Lakes at Valley West	P

Notes:

<sup>1</sup> Only one ADU per designated lot in Appendix C; one separated off-street parking space required for the second unit; occupancy may not exceed two persons or one bedroom; living area limited to 600 SF.

<sup>2</sup> Group living is subject to the requirements of the UDC.

<sup>3</sup> Home-based businesses are subject to the terms and thresholds of the UDC.

<sup>4</sup> Manufactured homes are subject to the standards of the UDC and must adhere to the architectural standards established by The Lakes at Valley West Design Manual.

<sup>5</sup> “Limited Two Household/Duplexes” (similar to attached ADUs) are allowed on designated lots in Appendix C; one separated off-street parking space is required for the second unit; occupancy may not exceed three persons or two bedrooms; living area is limited to one-third of the total square footage of the main residence.

**Sec. 3 - Lot coverage and floor area.**

- A. Maximum lot coverage by principal and accessory buildings shall be:
  - 1. Not more than 50 percent of the lot area
- B. Minimum floor area requirements for each dwelling in all districts shall be that area required by the city's adopted International Building Code.
- C. There are no FAR (floor area ratio) requirements for Phase 4.

**Sec. 4 - Lot area and width.**

- A. All lots shall have a minimum area as set forth in the table below and are cumulative. These minimums assume a lack of development constraints.

Table of Minimum Lot Areas for The Lakes at Valley West PUD	Minimum Lot Area (SF)
Single-household dwelling	2,500
Two-household dwelling (including "limited two-household/duplex")	2,250
Lot area <i>per townhouse</i> (including duplex townhomes and triplex townhomes)	2,500 (2,000 for interior unit)
Additional area required for a detached accessory dwelling unit	none
All other uses	5,000

- B. All lots shall have a minimum width as set forth in the table below. These minimums assume a lack of development constraints.

Table of Minimum Lot Widths for The Lakes at Valley West PUD	Minimum Lot Width
Single-household dwelling	25
Two-household dwelling	25
Accessory dwelling unit	none
Dwellings in three-household dwelling configurations	25
Townhouses	25
All other uses	50

**Sec. 5 - Yards.**

- A. Minimum yards required are:
  - 1. Any yard facing a street: 15 feet; 20 feet for garage doors
  - 2. Any yard facing a Woonerf: 15 feet; See Appendix C2 for garage door setbacks.
  - 3. Any yard facing open space: 5-20 feet (see Lot Exhibits in Appendix C2)



3. Any side yard: 5-12 feet; or zero feet for interior walls of townhouses (see Lot Exhibits in Appendix C2)

**B. Yard Encroachments:**

1. Side yards and/or Open Space yards.
  - c. Decks and patios must face only side yards and/or open spaces. Decks and patios may not extend more than 40 percent feet into any required side setback.

Setback	Deck/Patio Encroachment
5'	2'
7'	2'-9"
10'	4'
12'	4'-9"

2. Porches may encroach up to 5 feet into a 15' yard setback facing a street or 15' yard facing a Woonerf only if all four of the following conditions are met:
  - i. The encroaching porch must have a length equal to or greater than one-half the length of the building façade or 12 feet, whichever is greater. The remaining portion may be occupied by an integrated façade as defined in this Design Manual:
  - ii. The encroaching porch must have a minimum depth of six (6) feet;
  - iii. Second or subsequent stories are not allowed to encroach into the 15-foot street or Woonerf facing yard; and
  - iv. No stairs are permitted beyond the 10-foot setback.

**Sec. 6 - Building height.**

Maximum building height for each residential district shall be as follows:

Table of Heights for The Lakes at Valley West	Height (in feet)
Less than 3:12	34
3:12 or greater but less than 6:12	38
6:12 or greater but less than 9:12	42
Equal to or greater than 9:12	44

**Sec. 7 - Residential garages.**

- A. Attached residential garages facing a street shall not obscure the entrance to the dwelling. Attached garages are required to be clearly subordinate to the dwelling. A subordinate garage **has two or more** of the following characteristics:
  - 1. The principal facade of the dwelling is emphasized by using architectural features such as, but not limited to, porches, fenestration treatment, architectural details, height, orientation or gables, so that the non-garage portion of the residence is visually dominant;
  - 2. The facade with the garage vehicle entrance is recessed at least four feet behind the facade of the dwelling containing the main entry; **and/or**
  - 3. The area of the garage vehicle door comprises 30 percent or less of the total square footage, exclusive of any exposed roof areas, of the principal facade of the dwelling. Principal facade shall include all wall areas parallel to the garage door.
- B. Residential garages facing a woonerf are not required to meet the above criteria.

### **Sec. 8 – Parking**

- H. Street-accessed and woonerf-accessed driveways shall be of concrete, or built of brick or concrete pavers approved in advance by the DRP. Woonerf-accessed driveways may also be paved with asphalt, when approved, as an extension of the paved alley.
- I. Parking requirements in terms of the number and size of spaces are the same as the most current version of the UDC.
- J. Where a woonerf serves lots, access to garages and off-street parking shall be off the woonerf. In cases where a woonerf is not adjacent to a lot, accesses to garages are permitted to be off the street.
- K. Driveways are encouraged to be shared wherever possible to minimize street cuts and maximize on-street parking options.
- L. All “required” parking spaces must meet the minimum dimensions established in the UDC.
- M. Parking spaces shall not block sidewalks, woonerfs, driveways, accesses, pedestrian facilities or snow removal/plowing.
- N. The developer will provide parking spaces along the woonerf in several designated locations. Driveways must be located outside of these parking areas.

### **Sec. 9 - Minimum density.**

- A. New residential development shall provide a minimum net density of five dwellings per net acre. A minimum is required to support efficiency in use of land and provision of municipal services, and to advance the purposes and goals of this chapter and the City’s adopted growth policy. Density may be achieved by averaging lot sizes over the entire

Lakes at Valley West PUD area. For example, one phase or area may be less than five units per net acre while another may be greater than five units per net acre as long as the average is at least five units per net acre.

## **Sec. 10 – Architectural, Additional Site and Landscape Requirements**

- B. The Lakes at Valley West Design Manual includes additional site, architectural and landscape requirements that are all subject to review and approval by The Lakes at Valley West Design Review Panel. Appendix C3 of the Design Manual contains detailed lot exhibits that provide specific information per lot regarding uses, setbacks, etc.

## **Appendix A4**

### **ARTICLE 8 - PUD1 –THE LAKES AT VALLEY WEST PLANNED UNIT DEVELOPMENT (PUD) ZONING DISTRICT PHASE 5 & 6**

#### **Sec. 1 - Intent and purpose.**

A. The intent and purpose of the Lakes at Valley West Planned Unit Development (PUD) Phase 5 & 6 Residential Zoning District is to set forth certain standards for development within the PUD that vary from the Unified Development Code (UDC) typical residential zoning districts. Other relaxations from the UDC are detailed in the PUD application and are related to subdivision design. This District applies to all lots within The Lakes at Valley West. Future changes to the R-1 zone in UDC do not impact the subject properties.

1. The intent of the Lakes at Valley West residential density district is to provide for a variety of small lots for lower intensity single, two household residential development and related uses (including accessory dwelling units) within the city at urban densities in a master planned area and to provide for such community facilities and services as will serve the area's residents while respecting the residential character and quality of the area. It should provide for a variety of housing types to serve the varied needs of households of different size, age and character.

2. In exchange for relaxations, strict design standards have been established in The Lakes at Valley West Design Manual which is administered by The Lakes at Valley West Design Review Panel. Many of these standards are more stringent than the requirements of the UDC.

#### **Sec. 2 - Authorized uses.**

A. Uses are depicted in the table below. Appendix C in the Design Manual designates which lots are allowed which uses. Principal uses are indicated with a "P," conditional uses are indicated with a "C," accessory uses are indicated with an "A" and uses which are not permitted with the district are indicated by a "-." "C" uses require a Conditional Use Permit from the City of Bozeman but must receive approval from The Lakes at Valley West Design Review Panel prior to submitting any applications to the City.

B. Note that additional uses for telecommunication uses are contained in the UDC.

C. The uses listed are deliberately broad and some are given special definitions in the UDC. The intent of this method is to provide general guidance for uses while allowing the unique needs and circumstances of each proposal to be specifically addressed through the review process. Some uses are the subject of special regulations contained in the UDC.

<b>Table of Residential Uses for The Lakes at Valley West PUD- Phase 5 &amp; 6</b>	<b>Type of Use</b>
Accessory dwelling units <sup>1</sup>	P (only on specifically designated lots in Appendix C)
Community centers	C
Community residential facilities with eight or fewer	P
Cooperative housing	C
Day care centers	C
Essential services Type I	A
Essential services Type II	P
Essential services Type III	C
Family day care home	P
Fences	A
Greenhouses	A
Group day care home	C
Group living <sup>2</sup>	P
Guesthouses	A
Home-based businesses <sup>3</sup>	A/C
Other buildings and structures typically accessory to	A
Private garages	A
Private or jointly owned recreational facilities	A
Private stormwater control facilities	A
Public and private parks and park improvements	P
Manufactured homes on permanent foundations <sup>4</sup>	P
Single-household dwelling	P
Temporary buildings and yards incidental to	A
Temporary sales and office buildings	A
Two-household dwelling	P (only on specifically designated lots in Appendix C)
“Limited Two Household/Duplex” <sup>5</sup>	P (only on specifically designated lots in Appendix C)
Townhouses (two or three attached townhomes)	P (only on specifically designated lots in Appendix C)
Tool sheds for storage of domestic supplies	A
Uses approved as part of the Lakes at Valley West	P

Notes:

<sup>1</sup> Only one ADU per designated lot in Appendix C; one separated off-street parking space required for the second unit; occupancy may not exceed two persons or one bedroom; living area limited to 600 SF.

<sup>2</sup> Group living is subject to the requirements of the UDC.

<sup>3</sup> Home-based businesses are subject to the terms and thresholds of the UDC.

<sup>4</sup> Manufactured homes are subject to the standards of the UDC and must adhere to the architectural standards established by The Lakes at Valley West Design Manual.

<sup>5</sup> “Limited Two Household/Duplexes” (similar to attached ADUs) are allowed on designated lots in Appendix C; one separated off-street parking space is required for the second unit; occupancy may not exceed three persons or two bedrooms; living area is limited to one-third of the total square footage of the main residence.

**Sec. 3 - Lot coverage and floor area.**

- A. Maximum lot coverage by principal and accessory buildings shall be:
  - 1. Not more than 50 percent of the lot area
- B. Minimum floor area requirements for each dwelling in all districts shall be that area required by the city's adopted International Building Code.
- C. There are no FAR (floor area ratio) requirements for Phases 5 & 6.

**Sec. 4 - Lot area and width.**

- A. All lots shall have a minimum area as set forth in the table below and are cumulative. These minimums assume a lack of development constraints.

<b>Table of Minimum Lot Areas for The Lakes at Valley West PUD</b>	<b>Minimum Lot Area (SF)</b>
Single-household dwelling	2,500
Two-household dwelling (including "limited two-household/duplex")	2,250
Lot area <i>per townhouse</i> (including duplex townhomes and triplex townhomes)	2,500 (2,000 for interior unit)
Additional area required for a detached accessory dwelling unit	none
All other uses	5,000

- B. All lots shall have a minimum width as set forth in the table below. These minimums assume a lack of development constraints.

<b>Table of Minimum Lot Widths for The Lakes at Valley West PUD</b>	<b>Minimum Lot Width</b>
Single-household dwelling	25
Two-household dwelling	25
Accessory dwelling unit	none
Dwellings in three-household dwelling configurations	25
Townhouses	25
All other uses	50

**Sec. 5 - Yards.**

- A. Minimum yards required are:
  - 1. Any yard facing a street: 15 feet; 20 feet for garage doors
  - 2. Any yard facing a Woonerf: 15 feet; See Appendix C2 for garage door setbacks.

3. Any yard facing open space: 5-20 feet (see Lot Exhibits in Appendix C2)
4. Any side yard: 5-12 feet; or zero feet for interior walls of townhouses (see Lot Exhibits in Appendix C2)

**B. Yard Encroachments:**

1. Side yards and/or Open Space yards.

- a. Decks and patios must face only side yards and/or open spaces. Decks and patios may not extend more than 40 percent feet into any required side setback.

Setback	Deck/Patio Encroachment
5'	2'
7'	2'-9"
10'	4'
12'	4'-9"

- b. Phase 5 Lots 25-28 and 58-61; and Phase 6 Lots 1-8, first and second floor porches fronting parkland may encroach up to 5 feet into a 10' open space setback only if the covered deck exceeds 1/3 in length of the building.

2. Porches may encroach up to 5 feet into a 15' yard setback facing a street or 15' yard facing a Woonerf only if all four of the following conditions are met:

- i. The encroaching porch must have a length equal to or greater than one-half the length of the building façade or 12 feet, whichever is greater. The remaining portion may be occupied by an integrated façade as defined in this Design Manual:
- ii. The encroaching porch must have a minimum depth of six (6) feet;
- iii. Second or subsequent stories are not allowed to encroach into the 15-foot street or Woonerf facing yard; and
- iv. No stairs are permitted beyond the 10-foot setback.

**Sec. 6 - Building height.**

Maximum building height for each residential district shall be as follows:

Table of Heights for The Lakes at Valley West	Height (in feet)
Less than 3:12	34
3:12 or greater but less than 6:12	38
6:12 or greater but less than 9:12	42



**Sec. 7 - Residential garages.**

- A. Attached residential garages facing a street shall not obscure the entrance to the dwelling. Attached garages are required to be clearly subordinate to the dwelling. A subordinate garage **has two or more** of the following characteristics:
1. The principal facade of the dwelling is emphasized by using architectural features such as, but not limited to, porches, fenestration treatment, architectural details, height, orientation or gables, so that the non-garage portion of the residence is visually dominant;
  2. The facade with the garage vehicle entrance is recessed at least four feet behind the facade of the dwelling containing the main entry; **and/or**
  3. The area of the garage vehicle door comprises 30 percent or less of the total square footage, exclusive of any exposed roof areas, of the principal facade of the dwelling. Principal facade shall include all wall areas parallel to the garage door.
- B. Residential garages facing a woonerf are not required to meet the above criteria.

**Sec. 8 – Parking**

- O. Street-accessed and woonerf-accessed driveways shall be of concrete, or built of brick or concrete pavers approved in advance by the DRP. Woonerf-accessed driveways may also be paved with asphalt, when approved, as an extension of the paved alley.
- P. Parking requirements in terms of the number and size of spaces are the same as the most current version of the UDC.
- Q. Where a woonerf serves lots, access to garages and off-street parking shall be off the woonerf. In cases where a woonerf is not adjacent to a lot, accesses to garages are permitted to be off the street.
- R. Driveways are encouraged to be shared wherever possible to minimize street cuts and maximize on-street parking options.
- S. All “required” parking spaces must meet the minimum dimensions established in the UDC.
- T. Parking spaces shall not block sidewalks, woonerfs, driveways, accesses, pedestrian facilities or snow removal/plowing.
- U. The developer will provide parking spaces along the woonerf in several designated locations. Driveways must be located outside of these parking areas.

## **Sec. 9 - Minimum density.**

- A. New residential development shall provide a minimum net density of five dwellings per net acre. A minimum is required to support efficiency in use of land and provision of municipal services, and to advance the purposes and goals of this chapter and the City's adopted growth policy. Density may be achieved by averaging lot sizes over the entire Lakes at Valley West PUD area. For example, one phase or area may be less than five units per net acre while another may be greater than five units per net acre as long as the average is at least five units per net acre.

## **Sec. 10 – Architectural, Additional Site and Landscape Requirements**

- C. The Lakes at Valley West Design Manual includes additional site, architectural and landscape requirements that are all subject to review and approval by The Lakes at Valley West Design Review Panel. Appendix C3 of the Design Manual contains detailed lot exhibits that provide specific information per lot regarding uses, setbacks, etc.

## Sketch Design Review Application FORM 2

**Note:** Lots in Valley West (east of Cottonwood Road) must comply with all requirements of the Valley West Covenants. Lots in The Lakes (west of Cottonwood Road) must comply with all requirements of the Lakes Design Manual and the Valley West Covenants (excluding Articles IV, V, VI, VII & VIII).

**Property Information:**

Street Address: \_\_\_\_\_

Lot \_\_\_\_\_ Block \_\_\_\_\_ Phase \_\_\_\_\_

**Owner Information:**

Name: \_\_\_\_\_

Mailing Address: \_\_\_\_\_

Telephone: \_\_\_\_\_ FAX: \_\_\_\_\_

Email: \_\_\_\_\_

**Architect Information:**

Name: \_\_\_\_\_

Mailing Address: \_\_\_\_\_

Telephone: \_\_\_\_\_ FAX: \_\_\_\_\_

Email: \_\_\_\_\_

**Builder Information:**

Name: \_\_\_\_\_

Mailing Address: \_\_\_\_\_

Telephone: \_\_\_\_\_ FAX: \_\_\_\_\_

Email: \_\_\_\_\_

**Landscape Designer Information:**

Name: \_\_\_\_\_

Mailing Address: \_\_\_\_\_

Telephone: \_\_\_\_\_ FAX: \_\_\_\_\_

Email: \_\_\_\_\_

**Information:**

1. Are any variances from The Lakes at Valley West Design Manual or Valley West Architectural Regulations being requested under this application?

Yes

No

If yes, please describe the variance:

---

---

---

---

---

---

**Acknowledgement Statement:**

The Lot Owner acknowledges that he/she has received, read and will abide by the Design Manual for The Lakes at Valley West or Valley West Architectural Regulations.

As stated in the both the Covenants and Design Manual, violations will be remedied by The Lakes at Valley West or Valley West Homeowners' Association whereupon the Lot Owner will be responsible for the cost of the remedy.

I (We) \_\_\_\_\_ am/are the owner(s) of record \_\_\_\_\_ The Lakes at Valley West or Valley West. I/We have read these requirements and understand their implications. Furthermore, I (we) have been given sufficient opportunity to discuss any questions we may have regarding these requirements with a member of The Lakes at Valley West or Valley West Design Review Panel. My (Our) signature(s) below is/are evidence of my/our intent to comply with these requirements.

Owner Signature: \_\_\_\_\_ Date: \_\_\_\_\_

Printed Name: \_\_\_\_\_

Applicant Signature: \_\_\_\_\_ Date: \_\_\_\_\_

Printed Name: \_\_\_\_\_

# Construction Design Review Application

# FORM 3

**Note:** Lots in Valley West (east of Cottonwood Road) must comply with all requirements of the Valley West Covenants. Lots in The Lakes (west of Cottonwood Road) must comply with all requirements of the Lakes Design Manual and the Valley West Covenants (excluding Articles IV, V, VI, VII & VIII).

### Property Information:

Street Address: \_\_\_\_\_

Lot \_\_\_\_\_ Block \_\_\_\_\_ Phase \_\_\_\_\_

### Owner Information:

Name: \_\_\_\_\_

Mailing Address: \_\_\_\_\_

Telephone: \_\_\_\_\_ FAX: \_\_\_\_\_

Email: \_\_\_\_\_

### Architect Information:

Name: \_\_\_\_\_

Mailing Address: \_\_\_\_\_

Telephone: \_\_\_\_\_ FAX: \_\_\_\_\_

Email: \_\_\_\_\_

### Builder Information:

Name: \_\_\_\_\_

Mailing Address: \_\_\_\_\_

Telephone: \_\_\_\_\_ FAX: \_\_\_\_\_

Email: \_\_\_\_\_

### Landscape Designer Information:

Name: \_\_\_\_\_

Mailing Address: \_\_\_\_\_

Telephone: \_\_\_\_\_ FAX: \_\_\_\_\_

Email: \_\_\_\_\_

**Information:**

1. Are any variances from The Lakes at Valley West Design Manual or Valley West Architectural Regulations being requested under this application?

Yes

No

If yes, please describe the variance:

---

---

---

---

---

---

---

Signature: \_\_\_\_\_ Date: \_\_\_\_\_

Printed Name: \_\_\_\_\_



## Changes Application

## FORM 4

**Note:** Lots in Valley West (east of Cottonwood Road) must comply with all requirements of the Valley West Covenants. Lots in The Lakes (west of Cottonwood Road) must comply with all requirements of the Lakes Design Manual and the Valley West Covenants (excluding Articles IV, V, VI, VII & VIII).

### Property Information:

Street Address: \_\_\_\_\_

Lot \_\_\_\_\_ Block \_\_\_\_\_ Phase \_\_\_\_\_

### Owner Information:

Name: \_\_\_\_\_

Mailing Address: \_\_\_\_\_

Telephone: \_\_\_\_\_ FAX: \_\_\_\_\_

Email: \_\_\_\_\_

### Architect/Landscape Architect Information:

Name: \_\_\_\_\_

Mailing Address: \_\_\_\_\_

Telephone: \_\_\_\_\_ FAX: \_\_\_\_\_

Email: \_\_\_\_\_

### Builder Information:

Name: \_\_\_\_\_

Mailing Address: \_\_\_\_\_

Telephone: \_\_\_\_\_ FAX: \_\_\_\_\_

Email: \_\_\_\_\_

**Information:**

1. Has the requested change or modification already been constructed?

Yes

No

If yes, please explain:

---

---

---

---

---

---

---

2. Change Description and reason for change:

(Attach specific drawings of proposed change)

---

---

---

---

---

---

---

Signature: \_\_\_\_\_ Date: \_\_\_\_\_

Printed Name: \_\_\_\_\_

**Property Information:**

Street Address: \_\_\_\_\_

Lot \_\_\_\_\_ Block \_\_\_\_\_ Phase \_\_\_\_\_

**Owner Information:**

Name: \_\_\_\_\_

Mailing Address: \_\_\_\_\_

Telephone: \_\_\_\_\_ FAX: \_\_\_\_\_

Email: \_\_\_\_\_

**Architect Information:**

Name: \_\_\_\_\_

Mailing Address: \_\_\_\_\_

Telephone: \_\_\_\_\_ FAX: \_\_\_\_\_

Email: \_\_\_\_\_

**Builder Information:**

Name: \_\_\_\_\_

Mailing Address: \_\_\_\_\_

Telephone: \_\_\_\_\_ FAX: \_\_\_\_\_

Email: \_\_\_\_\_

**Landscape Designer Information:**

Name: \_\_\_\_\_

Mailing Address: \_\_\_\_\_

Telephone: \_\_\_\_\_ FAX: \_\_\_\_\_

Email: \_\_\_\_\_

**Certification:**

I do hereby certify that the contracted structure on said lot conforms to the codes and the construction documents as approved by The Lakes at Valley West and Valley West DRP. All site work, landscaping, cleaning, removal of temporary utilities, and repair of damage to rights-of-way and/or common areas have been implemented.

Signature: \_\_\_\_\_ Date: \_\_\_\_\_

Printed Name: \_\_\_\_\_

***For DRP use only:***

**Date of inspection:** \_\_\_\_\_

- Approved as noted in letter
- Denied as noted in letter

DRP Signature: \_\_\_\_\_

**If denied, subsequent inspection date:** \_\_\_\_\_

- Approved as noted in letter
- Denied as noted in letter

DRP Signature: \_\_\_\_\_

## **Appendix C1: The Lakes at Valley West, Phases 1 & 2 Building Envelopes**

The following lot exhibits describe allowable land uses, lot coverage, lot areas and widths, setbacks and driveway requirements.

## **Appendix C2: The Lakes at Valley West, Phase 3 Building Envelopes**

The following lot exhibits describe allowable land uses, lot coverage, lot areas and widths, setbacks and driveway requirements.

## **Appendix C3: The Lakes at Valley West, Phase 4 Building Envelopes**

The following lot exhibits describe allowable land uses, lot coverage, lot areas and widths, setbacks and driveway requirements.

## **Appendix C4: The Lakes at Valley West, Phase 5 & 6 Building Envelopes**

The following lot exhibits describe allowable land uses, lot coverage, lot areas and widths, setbacks and driveway requirements.



## **Appendix D: Woonerf Diagram**

The following diagram explains Section 6.3 Landscape: (a) Street / Woonerf Boulevard Plantings.

**Appendix E: The Lakes at Valley West Stormwater Maintenance Plan**

**Appendix F: The Lakes at Valley West Stormwater Maintenance Plan - Update**

**Appendix G: City of Bozeman Approval for Modifications August 16, 2018**